

CAULDRON[®]-150 Flame Proof

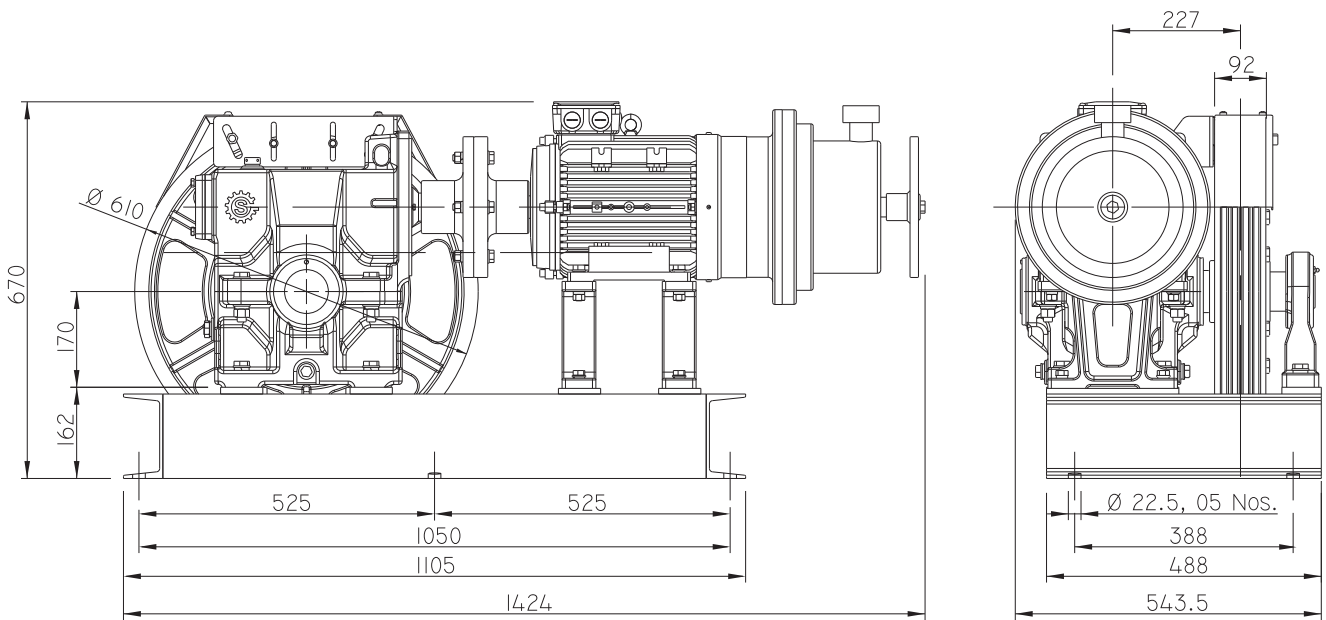
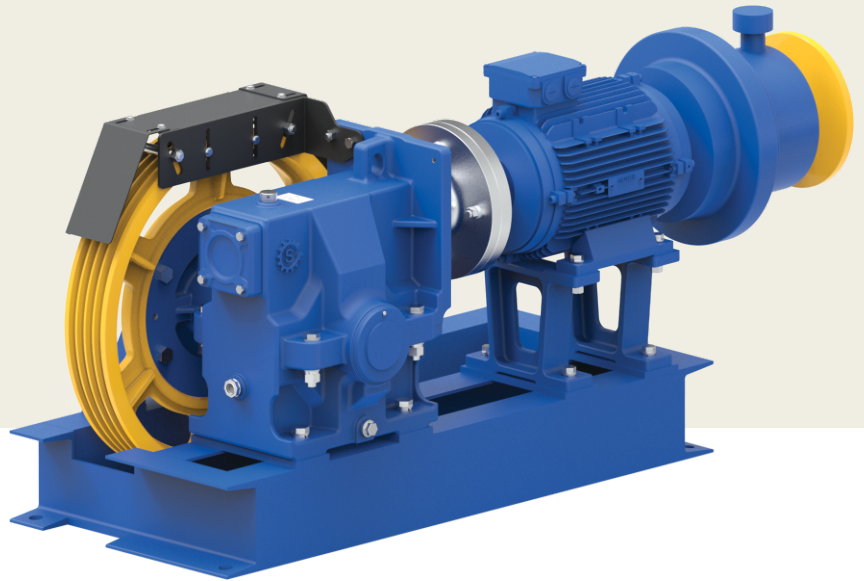

(All dimensions are in mm)

Roping 2:1 | Travelling : 15 mtr

Machine	Duty Load	Async. Speed	Gear Ratio	Motor Detail		RPM	Rated Current	Sheave Specification	Max. Allow Weight (Car + Car Frame + Operator)
	(Kg)	(m/sec)		(kw)	(HP)			Sheave Dia X Rope Dia X No. of Groove	(Kg)
CAULDRON 150	1500	0.5	1/49	7.5	10.0	1440	16.0	Ø610 X 13mm X 4 Grv	1000