



USER'S GUIDE

MP Series

C

EARED
Traction Machine

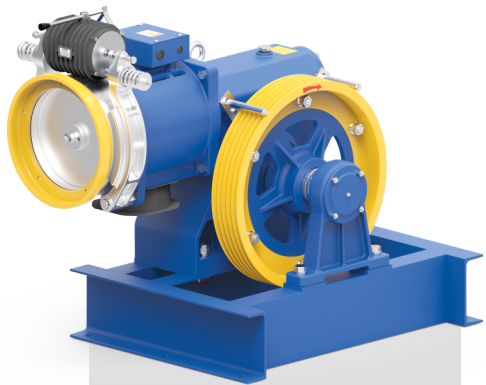

The **Quality** Inspires Trust



WARRANTY CERTIFICATE

OWNER DETAILS

Customer Name:

Address:

City:

State:

Pin Code:

Country:

Telephone No:

Cell No:

E-Mail ID:

MACHINE DETAILS

Model No:

Machine Serial No:

Motor Serial No:

Warranty Start Date:

Warranty Expiry Date:

Agent:

Sr No.	Description	Page No.
(1)	Warranty Certificate	01.
(2)	About the use of Traction Machine	03.
(3)	General Instructions	03.
	EMC Directive	03.
	Copy Right Low	03.
	Sign - Symbol - Interpretation & Meaning	04.
(4)	TECHNICAL DRAWING	
	MP-61	05.
	MP-61 R1	06.
	SIDERON	07.
	MM-79	08.
	BISON	09.
	Tusker	10.
(5)	Machine Identification	11.
(6)	Gear Box and Motor Data Plate	12.
(7)	Safety Precaution	13.
(8)	Packing, Transport & Storage	14. to 18.
	(A) JUNGLE WOOD PACKING	
	(B) PLAYWOOD PACKING	
(9)	Installation Area Information	19.
(10)	Lubrication	20.
(11)	Electrical Connection	21. to 23
(12)	Thermal Protection of Motor	24.
(13)	Operation of Traction Unit	25. / 26.
(14)	How To Fix Encoder (Optional)	27.
(15)	Adjustment of Brake	28./19.
(16)	How to Replace Brake Arm	30.
(18)	How to Replace Electric Motor	31.
(19)	How to Replace Thrust Bearing	32.
(20)	How to Replace Main Sheave	33.
(21)	Maintenance	34.
(22)	Manual Operation in case of Emergency	35.
(23)	Trouble Shooting	36.
(24)	Disposal Method of Machine After Coddle Life	37.
(25)	Optional Accessories	38.
(26)	Warranty	39.



CAUTION

ABOUT THE USE OF TRACTION MACHINE

Traction machines are not Ready-to-use products and May only be Operated after having been installed with other incorporated parts/spares/ Machines or plants and established with their Protective grating, barriers, constructive Devices provides as per respective E U Directives and national and local Law,

General Instructions

This Manual is part of the drive and must always be kept in its vicinity for reference at all the times. All persons involved in installation, operation, maintenance or repair of the drive must have read & understood this manual. Sharp Engineers takes no responsibility for damage or disruption caused by disregard of this manual.



EMC Directive

The adherence to the EMC directive 2004/108/EC only pertains to this product if Motors tested and recommended by Sharp Engineers are used, which have been installed in accordance with corresponding motor description and in line with the EMC. If the product is integrated unprofessionally into a system or completed by and operated with components (e.g. regulators and controllers, other electronic circuit devices) which have not been recommended, the operator of the complete system alone shall be responsible for adhering to the EMC directive.



© Copy Write

The copyright to this manual is held by Sharp Engineers, G.I.D.C. Kathwada, Ahmedabad-382430. Gujarat. India.

This manual must not be wholly or partly reproduced for competitive purposes, or used in any unauthorized way or made available to third parties without our permission.

SAFETY SIGN-SYMBOL- INTERPRETATION & MEANING

- Before Using the Traction Unit , read these “Precautions” thoroughly and operate in the correct way.
- The instructions in this section all relate to safety; be sure to maintain safe operation conditions.
- “Danger”, “Warning” and “Caution” have the following meanings in these instructions.



DANGER

This make indicates procedures which, if improperly performed, are most likely to result in the death of serious injury to the users or service personnel



WARNING

This make indicates procedures which, if improperly performed, might lead to the death or serious injury of the users



CAUTION

This make indicates procedures which, if improperly performed, might possibly result in personal harm to the users, or Damage to property.

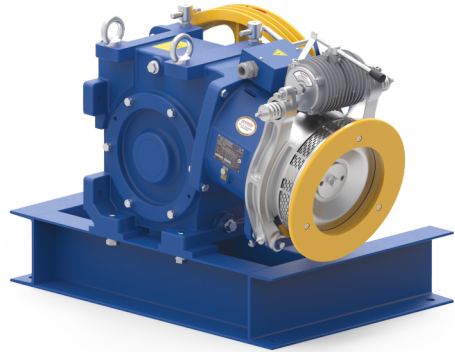

Technical Drawing

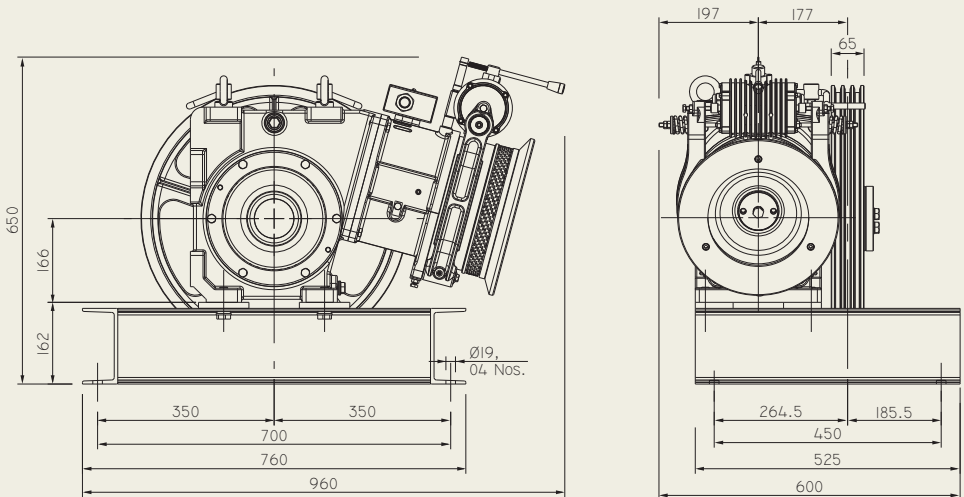

(All dimensions are in mm)

Weight of Machine (kg) : 255*

* Wight of machine is varies according to selection of sheave, motor & brake.

Subject to change without any prior notice!

MP61-R1

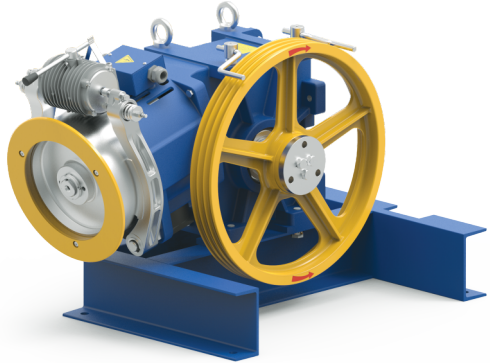

Technical Drawing

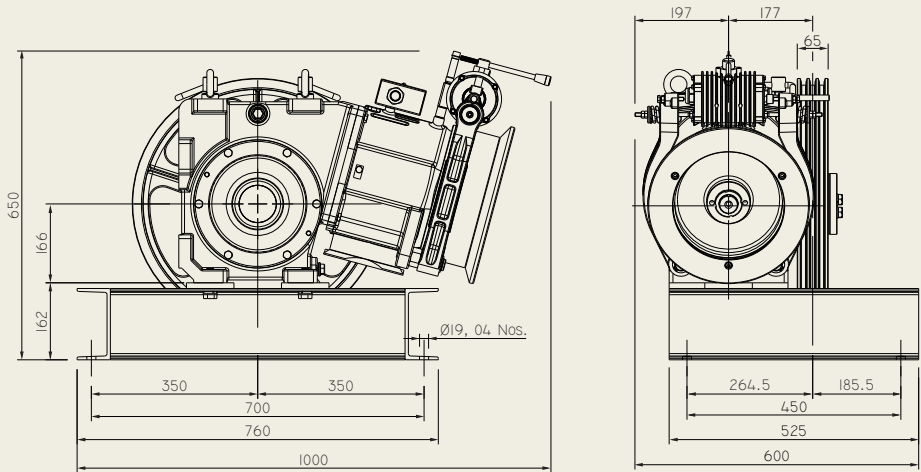

(All dimensions are in mm)

Weight of Machine (kg) : 262*

* Wight of machine is varies according to selection of sheave, motor & brake.

Subject to change without any prior notice!

Sideron

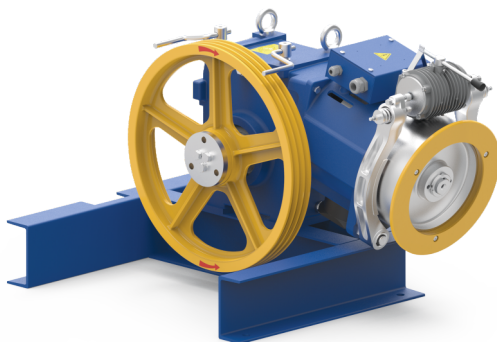

Technical Drawing

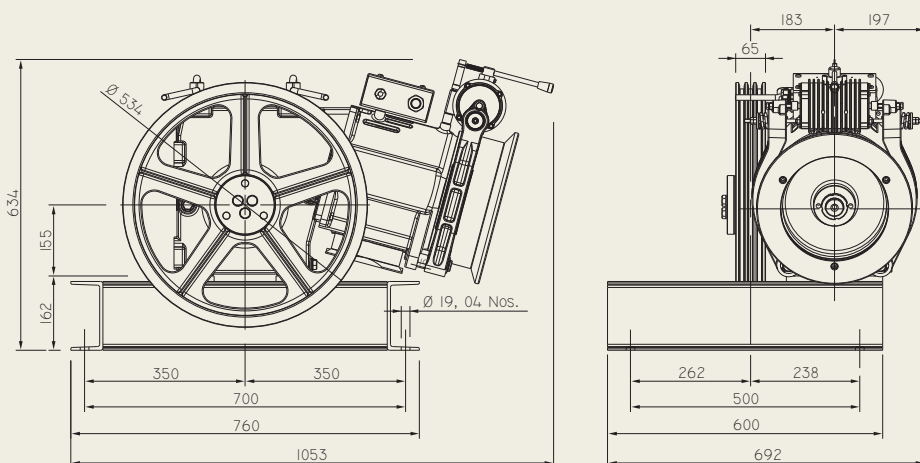

(All dimensions are in mm)

Weight of Machine (kg) : 315*

* Wight of machine is varies according to selection of sheave, motor & brake.

Subject to change without any prior notice!

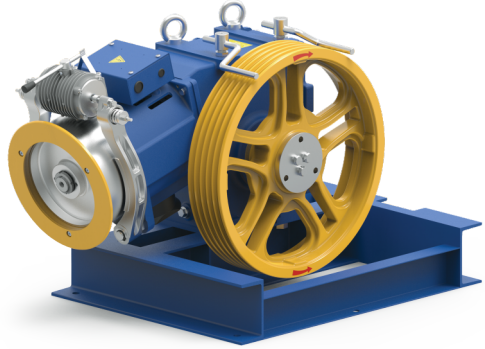

Technical Drawing

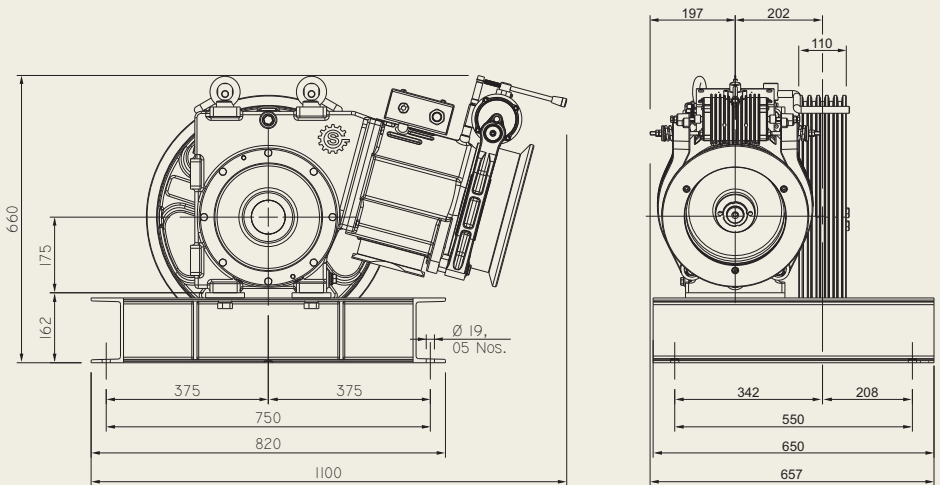

(All dimensions are in mm)

Weight of Machine (kg) : 367*

* Wight of machine is varies according to selection of sheave, motor & brake.

Subject to change without any prior notice!

BI SON™

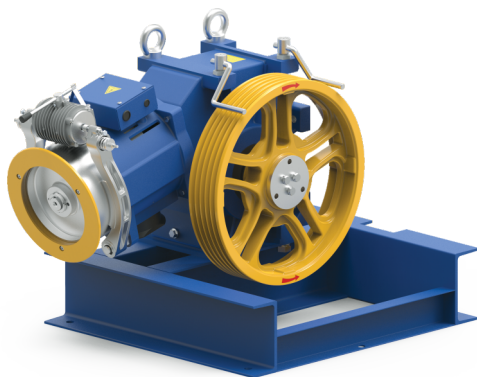

Technical Drawing

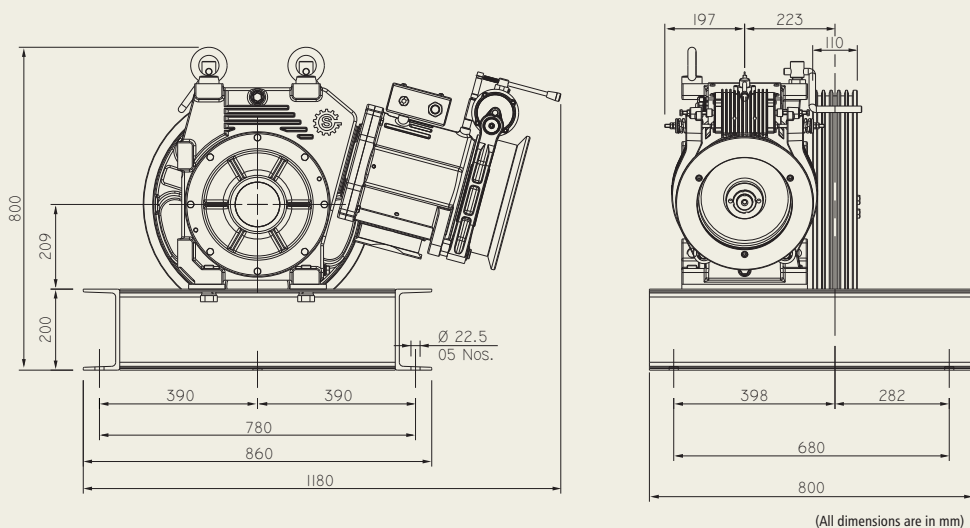

Weight of Machine (kg) : 461*

* Wight of machine is varies according to selection of sheave, motor & brake.

Subject to change without any prior notice!

tusker

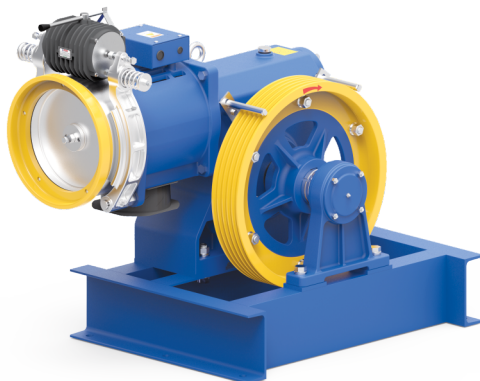

Technical Drawing

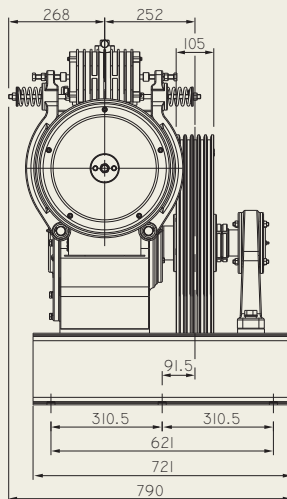
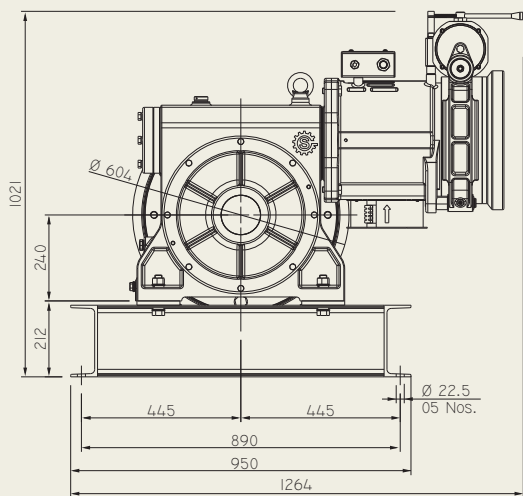

(All dimensions are in mm)

Weight of Machine (kg) : 600*

* Wight of machine is varies according to selection of sheave, motor & brake.

Subject to change without any prior notice!

Machine Identification

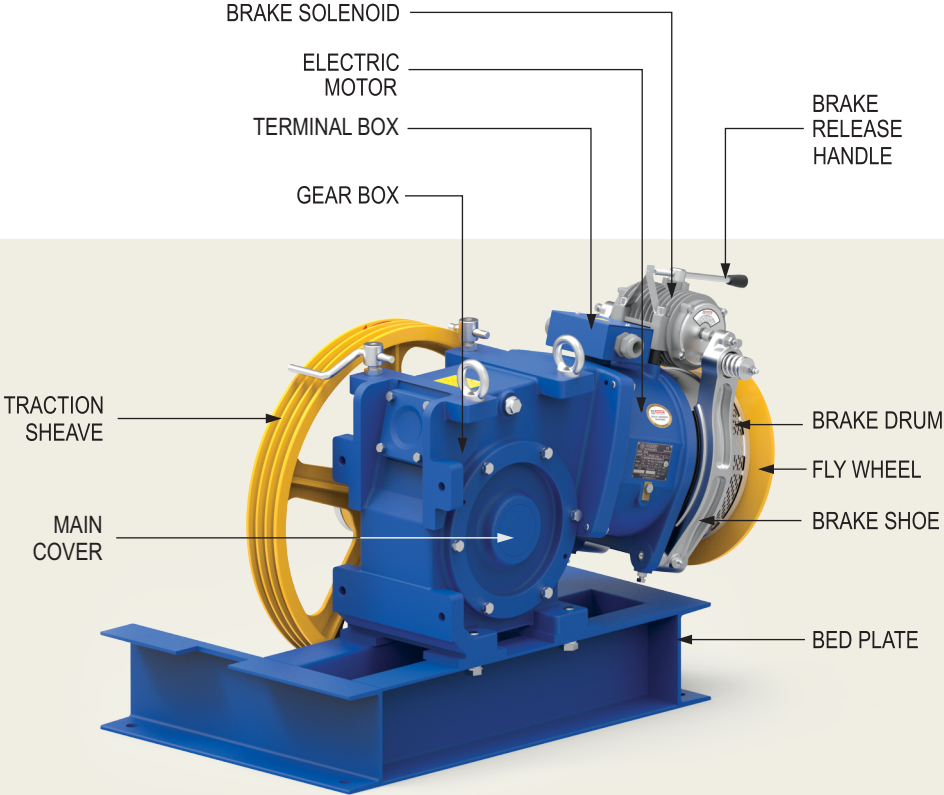

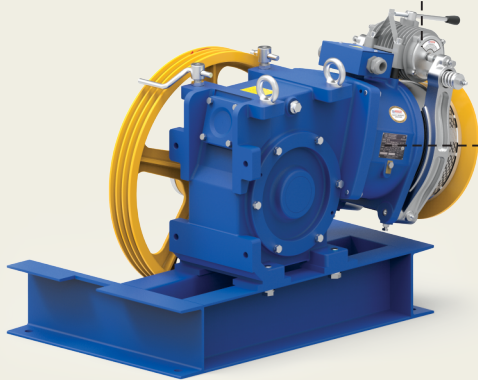

GEAR BOX AND MOTOR DATA PLATE

EXAMPLE OF THE PLATE ON THE MACHINE WHICH MAY VARY IN QUANTITY AND POSITION IN ACCORDANCE WITH THE CONFIGURATION*



 SHARP ENGINEERS AHMEDABAD, INDIA	
D.C. ELECTROMAGNETIC BRAKE	
DOUBLE ACTING TYPE	D.C. VOLTAGE : 110 V
RESISTANCE : 95 Ohms.	INSULATION : "F" CLASS

 BISON™		 ISO 9001:2015
GEAR RATIO :- 1/46	STATIC LOAD :- 4400 kg	OIL :- 6.0 ltr
A.C. INDUCTION MOTOR FOR DRIVING LIFT		
POWER = 11.0 Kw	380 V , 50 Hz , 3Ø	COSØ = 0.83
RPM = 1445	TYPE = VVVF	TORQUE (T) = 72.4 Nm
CURRENT (A) = 21.6	EFFICIENCY (%) = 88.8	
PROTECTION = IP 20	INSULATION = "F" CLASS	
SR NO.	MONTH & YEAR :-	ST/H = 240
BISON - A2	10 / 2012	DUTY = S1
SHARP ENGINEERS - GUJARAT (INDIA) www.sharpengineers.com		

BISON VVVF NAME PLATE

SAFETY PRECAUTION:

WARNING

- The traction unit should be installed in an area that is strictly kept under lock and key surveillance, Access to this area must be exclusively limited to a qualified installation & maintenance person who has been authorized by the user. At least the following notice must be affixed to the door that provides access to this area.

Lift machinery DANGER use by Authorized Personnel only.

- Before the traction unit is installed, the user must make sure that the floor slab & support systems for moving loads and for the Traction unit itself offer the required safety factors. The user MUST also respect the distance from walls or other machines that is specified in the directives or standards which apply in the country where the Traction unit is installed.
- Before performing any cleaning, lubrication and/or maintenance operations, the maintenance worker must remove the Traction unit from service by switching off the power supply and allow the hot motor and the Traction unit itself to cool down to ambient temperature.
- Do not rest against or sit on the Traction unit, whether it is in service or out-of-service.
- Do not approach or lean against rotating parts (Flywheel or Traction-Sheave yellow painted).
- Do not rest objects, containers of liquids, etc. on the Traction unit on its electrical components.
- Never temper with or deactivate the safety systems. Also, never bypass these systems or use them for purposes other than those for which they are intended.
- Do not tamper, degrade or remove the identification plates. If a plate should deteriorate and become illegible, contact SHARP ENGINEERS immediately for a replacement.
- When working around the traction unit the installation and maintenance person MUST NEVER WEAR FLUTTERING AND/OR TORN CLOTHING (i.e., scarves, ties, hats, necklaces, straps, watches, bracelets around the wrists, rings on the fingers, etc.)
- Warning refers to a hazard or unsafe method or practice which CAN result in service personal injury or possible death.
- Depended on the working conditions the surface temperature can be very high.

Danger of Burns !

- Temperature sensor installed into the winding serve as motor protection and must be connected to thermistor Protection Relay. [See Fig no. 06. Page no.25]
- Planners, manufacturers and operators of system, parts or entire systems are responsible for the correct and safe installation and a reliable operation.

DANGER

- Do not lift higher loads with these eyelets for example a socket, ropes, etc.

Danger of life !

- Safety components, e.g. the brake release monitoring, may neither be disassembled nor by-passed or disabled?

PACKING, TRANSPORT & STORAGE

JUNGLE WOOD PACKING

PACKING & TRANSPORT



1

Bottom Pallet

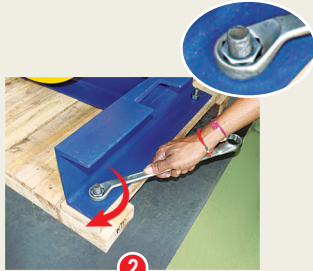

2

Bottom Pallet With
Mounting Bolts

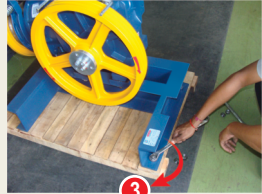

3

Traction Machine Placement



4

Plastic Packing



5

Nailing The Bottom



6

Complete Packing



7

Transport The Complete Packing

OPENING THE JUNGLE WOOD CRATES

The nails must be removed to open the jungle woods crates. In order to prevent the wood from splintering, use the tool shown in figure. This Special tool is a right-angle tube. its short end has a V shaped groove with a shrapened edge. Place the centre of the sharpened side on the nail and strike the tube with a hammer until the lip is inserted in the wood, then turn the tube using the tube elbow as leverage so that the nail head is lifted upwards. continue lifting so that the nail head fits into the v groove and is then removed.



REMOVAL FROM PACKING & HANDLING OF TRACTION MACHINE



8

Opening Crate

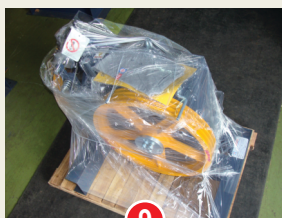

9

Open Plastic Packing & Vci Cover



10

Remove Mounting Bolts



11

Tighten The Lifting Belt Before
Remove Traction Machine
From Channels

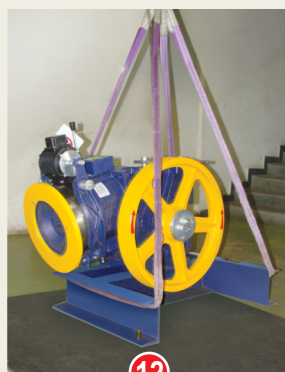

12

Lift Traction Machine
& Put In Machine Room

TRANSPORT & STORAGE

- Transport the motor(s)-(Traction Machine) either with the original packing or at the coasted eyelets using adequate hoists.
- Avoid impacts and shocks
- Check packing and motor for possible damage and report the forwarding agency about any damages caused by transport. Shipping damages are not covered under our guarantee.
- Store the motor in a dry, weatherproof place in its original packing or protect it from dirt and climatic influences until the final installation.
- Avoid extreme heat or cold (storage temperature between -20°C to $+60^{\circ}\text{C}$)
- Avoid excessive storage times (we recommend max one year) and check motor bearing for correct function before installing the motor. (Ease the brakes and move the rotor by hand. Take care if the bearing makes unusual noise)

PACKING, TRANSPORT & STORAGE

PLAYWOOD PACKING

PACKING & TRANSPORT

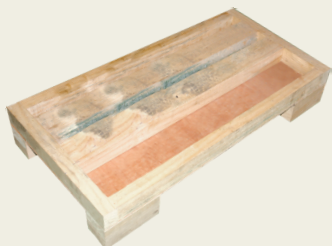

1

BOTTOM PALLET



2

BOTTOM PALLET WITH MOUNTING C CHANNEL



3

TRACTION MACHINE PLACEMENT



4

VCI COVER



5

PLASTIC COVER



6

CRATE PLACEMENT



7

NAILING TH BOTTOM



8

COMPLETE PACKING



9

TRANSPORT THE COMPLETE PACKING

OPENING THE PLAYWOOD CRATES

The nails must be removed to open the playwood crates. In order to prevent the palywood from splintering, use the tool shown in figure. This Special tool is a right-angle tube. its short end has a V shaped groove with a shrpned edge. Place the centre of the sharpened side on the nail and strike the tube with a hammer until the lip is inserted in the wood, then turn the tube using the tube elbow as leverage so that the nail head is lifted upwards. continue lifting so that the nail head fits into the v groove and is then removed.

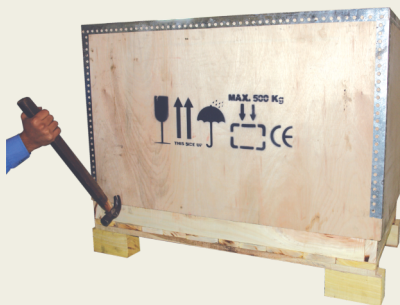

REMOVAL FROM PACKING & HANDLING OF TRACTION MACHINE



1

OPEN THE CRATE



2

OPEN PLASTIC COVER & VCI COVER

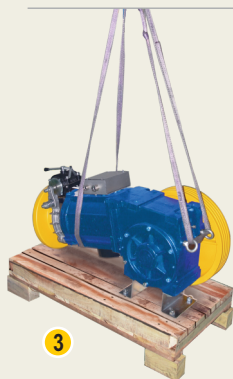

3

TIGHTEN THE LIFTING BELT BEFORE REMOVE TRACTION MACHINE FROM CHANNELS

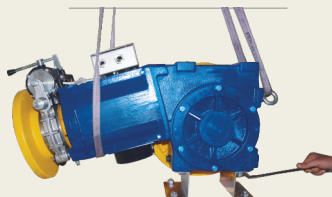

4

REMOVE TRACTION MACHINE FROM CHANNELS



5

5. LIFT TRACTION MACHINE & PUT IN MACHINE ROOM

INSTALLATION AREA INFORMATION

IMPORTANT

The area where the Traction Unit is installed must have the following characteristics:



It must be dry and free from dust:

This condition is indispensable for preventing high concentrations of water in the lubrication oil and electro-chemical corrosion of mechanical components.



It must be Well-Ventilated:

The installation area must be sufficiently open to the outside, or equipped with suitable means for providing sufficient air circulation to dissipate the heat from the motor and reduction unit.



Before Starting Installation:

The Unit must be checked for transport damages Of Mechanical Components.



Temperature:

The Temperature in the installation area must be between 5°C and 40°C. For operation under different temperature conditions

INSTALLATION

- Machine should be installed on ground 'I' section or 'C' channel with anti vibration rubber pad.
- Machine should be correct vertically along with respect to Elevator
- Put correct amount & grade of oil in Gear box, to refer Lubrication (See Table no. 01 & Page 21.)
- Follow given instruction drawing of motor connection inside terminal box cover.

LUBRICATION

SYNTHETIC OIL				
BRAND	KLUBER	SHELL	AGIP	MOBIL
TYPE	GH 6 - 220	OMALA S4 WE - 220	BLASIA S 220	GLYGOYLE 220

Table No. 01

OIL CHANGE

For synthetic oils every 24/36 months depending on the intensity of use. More frequent changes could be advisable in machines subject to high duty. (With the oils indicated in the chart is possible to foresee a slightly higher viscosity (ISO 320) in those gears subject to high duty.

START UP

The Machine mounted on steel frame is usually supported by heavy concrete beams with extensive vibration dumping properties between the machine frame and the supporting Beams, rubber pads or silent blocks are inserted having the characteristic of a rubber pad spring. This Situation are function as a vibration absorber.

IMPORTANT

The application of loads without following the specific instructions as described in the User's manual could cause serious damage to the gear unit even on initial operation, therefore during installation please adhere to our recommendations before running the gear.

Do not mix mineral oil with synthetic oil. In case of replacement of mineral oil with synthetic oil, strictly follow the instructions present in the User's manual.

Use Only Synthetic Oil





CAUTION

ELECTRICAL CONNECTION

For STELLAR-125

Refer Below Connection Diagram

Star Winding

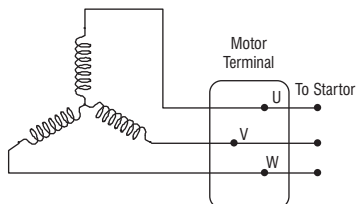

Connection Diagram

To Reverse Direction of Rotation
Change any two of the Three Line Loads

Fig No. 01

For MP-61

Refer Below Connection Diagram

Connection Diagram

For Fan 230 V 50Hz AC Supply
- +

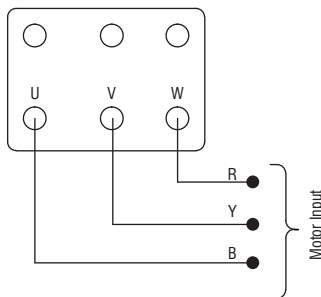

Fig No. 02

For MP-61 R1, Sideron, MM-79, Bison.

Refer Below Connection Diagram For 4 Pole Motor

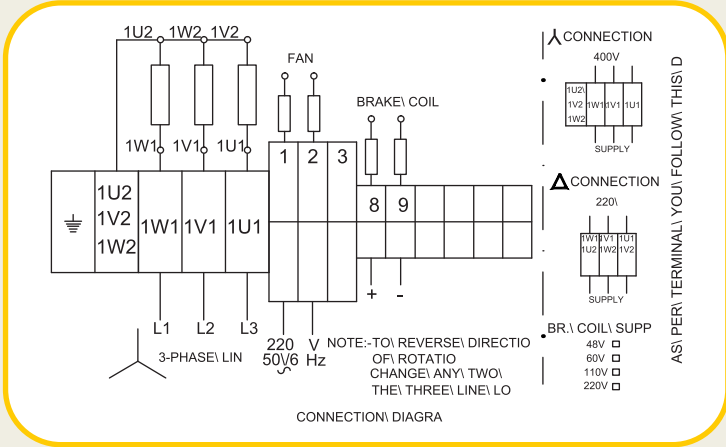

Fig No. 03

Refer Below Connection Diagram For 6 Pole Motor

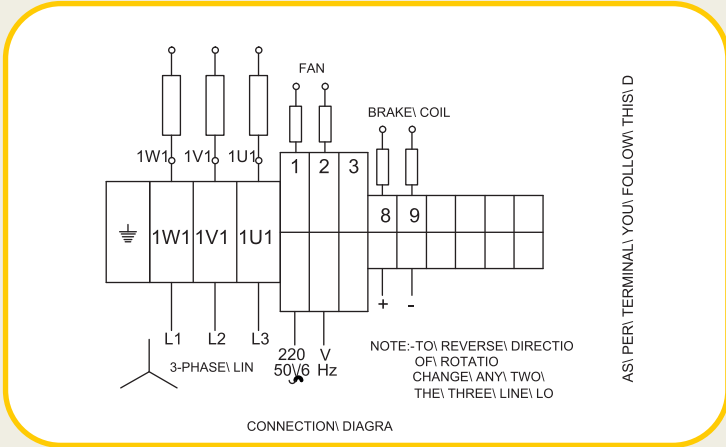

Fig No. 04

Connection Diagram For Ac2 4/16 Pole Motor with Thermistor

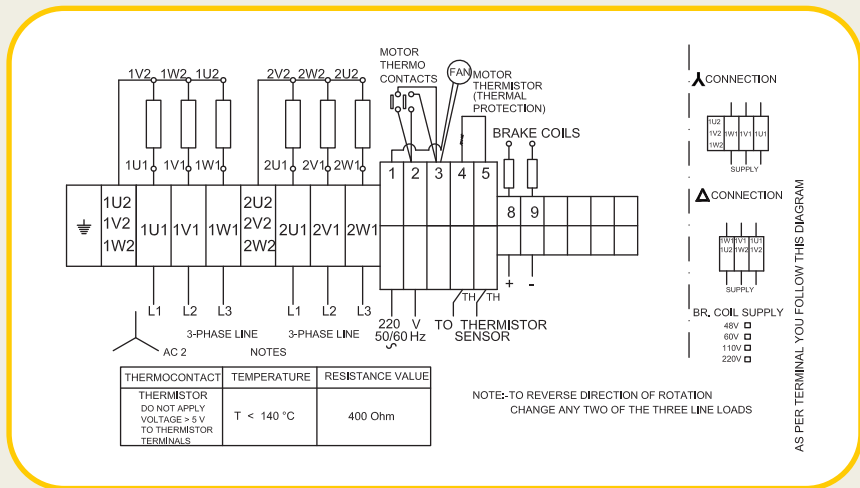

Fig No. 05

Connection Diagram For VVVF 4 Pole Motor with Thermistor

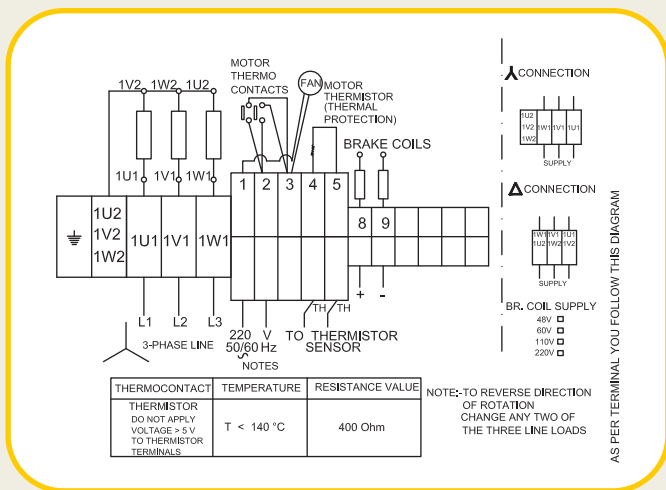

Fig No. 06

THERMAL PROTECTION OF MOTOR (OPTIONAL)

The Root Cause of Motor Failures

The Basic cause of motor burnout is Overheating up to unacceptable temperatures. Excessive temperature leads to insulation breakdown and ultimately to the burning of stator windings. Normally Class B and Class F motors are used in Elevators & they are operated close to limiting temperatures, Hence following conditions lead to motor failure.

- Single Phasing ● Under / Over Voltage
- Continuous Overloading ● Intermittent duty or excessive Start / Stops. ● Insufficient ventilation or excessive ambient temp. ● Mechanical Jamming / Overloading ● Bearing failure

All these Causes lead to excessive heating and ultimate burning of the winding.

PTC Sensor offers protection for your motor against all the above causes of Failures. Its superiority lies in the fact it eliminates the root cause of failure.

Functional Description

- The PTC Sensors are normally embedded in the motor windings. Normally 1 set of Sensors consists of 3 connected in series (1 thermistor per phase). These thermistors are to be connected to the respective terminal on the thermistor protection relay.
- Under normal temperature conditions, the Relay permits supply to the starter coil of motor whenever the tripping temperature is attained it cuts of the supply to the starter coil & trips the motor. When the winding temperature reduces below a safe level, the Relay resets and restores the supply to starter coil. Thus the winding of motor is protected from overheating and burning.

Require Relay for PTC Sensor.

Technical Data

Supply Voltage	110/230/380/415 VAC ± 10% 50 Hz 24 VDC ± 10 %
Output Contacts	2 Change over (2 No + 2NC) Potential Free
Input	Max. 6 numbers RTC Thermistors
Rated at	4 Amps 230 Volts.
Ambient Temp	-5 °C to + 55 °C
Operational Lift	1 million on / of Operations.

Table No.02

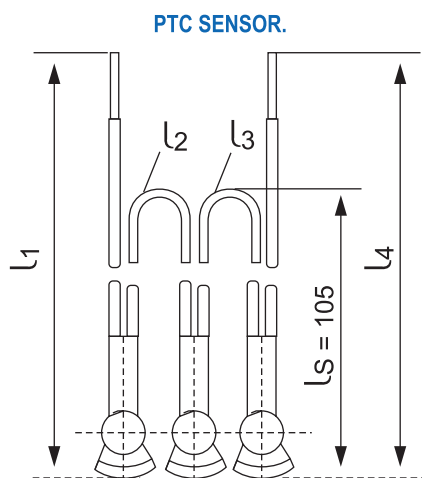

Fig No. 07

OPERATION OF TRACTION UNIT

IMPORTANT

- (1) Manually check that the machine (without loads) runs correctly in both Directions.
- (2) To ensure that the oil flows without obstructions, run the gear, without loads, electrically for 3 minutes in each direction.
- (3) Install the ropes on the sheave and load the cabin with half load in cabin and then repeat procedure see point ❶ this check helps to find out an anomalous frame bending underneath the external support.
- (4) (Important:) do not immediately run the installation with the empty cabin.
- (5) Also avoid long travels during maintenance.
- (6) Load the cabin with half of duty load see point ❸ check the correct balancing of the counterweight and measure the current absorbed by the motor at half travel in both running directions: they must always be the same.
- (7) Load the cabin with 60% of duty load and carry out 20 travels (not very long) at intermediate floors, keeping the hole for oil inlet open to check for smoke. Stop the installation and let the gear get cool.
- (8) Load the cabin with 75% of duty load and carry out 20 travels alternating many short travels upwards and downwards to few long travels with the cabin moving upwards.
- (9) Check again for smoke coming out from the oil inlet plug. With high running temperature oil could slightly vaporize, thus creating a fine mist: this phenomenon is not dangerous; in case of thick vapour stop the installation and let the machine get cool before repeat test travels. Should the mist disappear with cooler machine, repeat the running in increasing the loads, or slightly decrease the load in cabin (5% at the time) till

the phenomenon stops. Then gradually load to 75%. This running-in phase has to last for about 10 working hours and must be alternated with stops to cool the system.

- (10) Load the cabin with 90% of duty load and repeat the procedure of the previous point.
- (11) Load the gear with 100%. The machine has to be at room temperature carry out short travels for 10-15 minutes. Checking for smoke from oil inlet hole. Should vapour appears, repeat the procedures of point 8 or proceed directly with what indicated in point 7 following the same operations with the same duration.
- (12) With cold gear, download the cabin leaving 40 % of duty seen with 60 % of duty load. see point 6
- (13) Then, with cold gear download the cabin again leaving 25 % of duty load and follow the procedure indicated at. point 7 for duty load at 75%.
- (14) Load the cabin with 10 % of duty load with cold gear repeat what seen for 90 % see point 8
- (15) Then, with cold gear, download completely the cabin and repeat what seen under full load conditions. see point 9

N.B For Testing of traction unit with load , use hoist or other similar device instead of Traction unit Motor, It may be a cause to damage of gear.

HOW TO FIX ENCODER (OPTIONAL)

- First remove Alen bolt ① with spring washer.
- Then after remove the pressure cover ② .
- Fix the pin encoder ③ in worm shaft ④ .
- Then remount pressure cover.
- Fix the plate encoder ⑤ with encoder ⑥ .
- Pass one alen bolt in plate encoder and tight allen bolts.

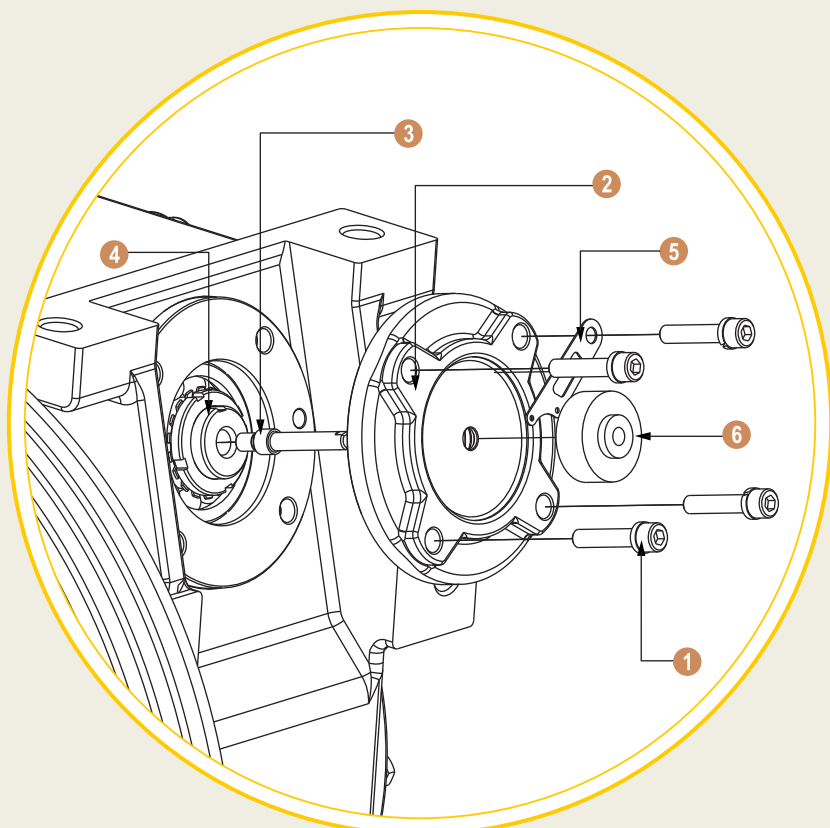

Fig No. 08

Note : For more detail regarding encoder specification please ask our technical team.



CAUTION ADJUSTMENT OF BRAKE

Measures before installing the elevator suspension ropes:

Check that the brake has no damage caused during transportation

Loosen and remove the nuts ④ and ③, then remove the protection paper of the brake drum and of brake linings.

Secure the adjustment by means of the locknut ④.

Adjust the stroke; see "Adjustment of stroke"

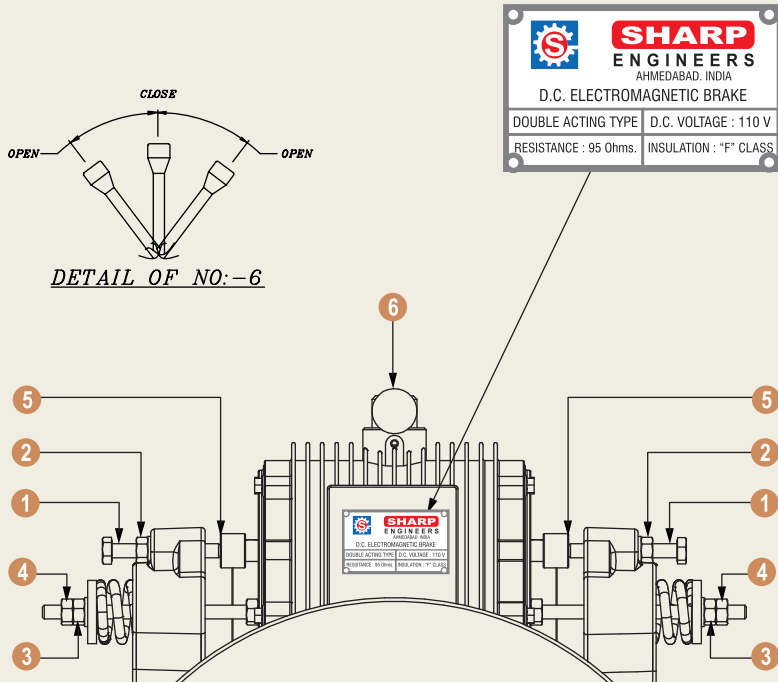

Fig No. 09

NOTE :

The brake is provided with two separate magnets. The brake shoes operate independently.

1.Adjustment of Stroke

Loosen a small locknut ② of both the brake shoes and screw out the adjusting screws ① so that a clearance of 4-5 mm remains between the screw and the magnet pin cups ⑤ Open the lever manually ⑥ to the position “open” and hold it in the same position. Screw in both adjusting screws ① manually so that they are against the magnet pin cups ⑤ Open the lever manually ⑥ to the position “closed” and screw in the adjusting screws still for ½ of a turn against the magnet pin cups. Tighten the locknut ②

2. Checking the Adjustment

Drive the car up and down and observe the noise., if the brake linings do not touch the brake wheel while the elevator is moving and no noise occurs at braking. The stroke is correctly adjusted.

3. Adjustment of braking torque:

The braking torque is adjusted with an empty car. Screw out the locknuts ④ Check the braking distance. If the braking distance is too short, loosen the springs by means of the nut ③ If the braking distance is too long, tighten the springs by means of the nut ③ At the correct braking distance, check that the springs are equally long; secure the adjustment by means of the locknut ④ This way you can replace new Brake arm.

4. Checking the stroke:-

Make sure that the manual opening lever ⑥ is “closed”. Push the magnet pin cup ⑤ in against the magnet manually, as far as possible and measure then the clearance between the adjusting screw ① and the magnet pin cup ⑤ If it is < 0.5 mm, the stroke must be adjusted immediately.

HOW TO REPLACE BRAKE ARM

- Remove Alen bolt 1 and then remove flywheel 2.
- Then remove brake arm spring by means of remove spring retainer 3 and nuts.
- After remove circlip 4 from brake stud 5 and replace brake arm 6 and follow reverse process.

Lift Machinery  **DANGER** use by Authorized Personnel only

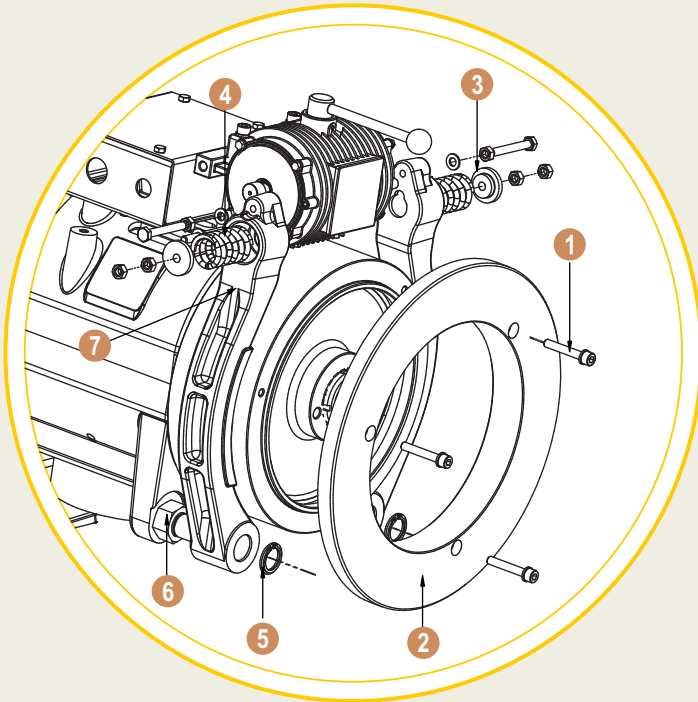

Fig No. 10

HOW TO REPLACE ELECTRIC MOTOR

- Remove alen bolt 1 then remove flywheel 2 .
- Removing nut, spring retainer, spring 3 and spring stud from solenoid 4 .
- Then remove brake arm 5 and remove brake stud 6 from both side.
- Remove two lock nuts 7 and remove brake drum 8 .
- Remove solenoid alen bolt 9 from motorbody 10 and remove solenoid.
- Remove alen bolt 11 . Then remove motor from gear housing.
- After replacing motor repeat cycle.

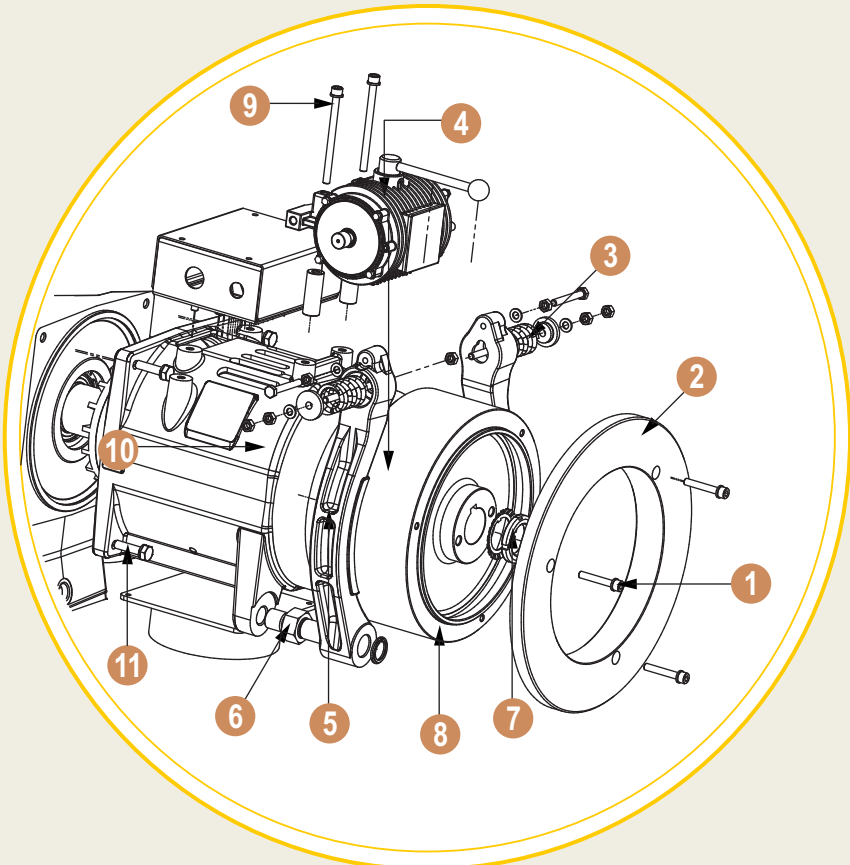

Fig No. 11

HOW TO REPLACE THRUST BEARING

- Remove allen bolt ① and then remove pressure cover ② .
- Remove lock nut ③ and star washer ④ .
- Remove bearing cover ⑤ and remove bearing ⑥ and replace.

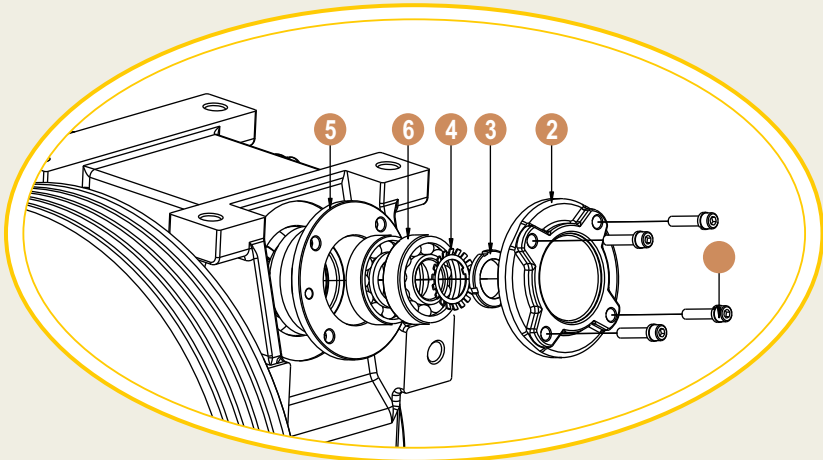
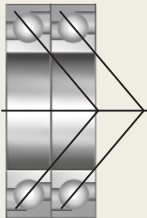
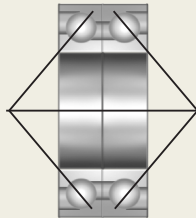

Fig No. 12

ARRANGEMENT OF BEARINGS



Tandem



Back to back

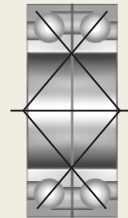

Face to face



HOW TO REPLACE MAIN SHEAVE

- Remove alen bolt **1** and then remove pulley washer **2**.
- Then put distance piece between pulley washer & main shaft.
- Match pulley washer hole to main Sheave face and tighten the alen bolt.
- Sheave **3** move outside, new replace sheave and follow reverse process.

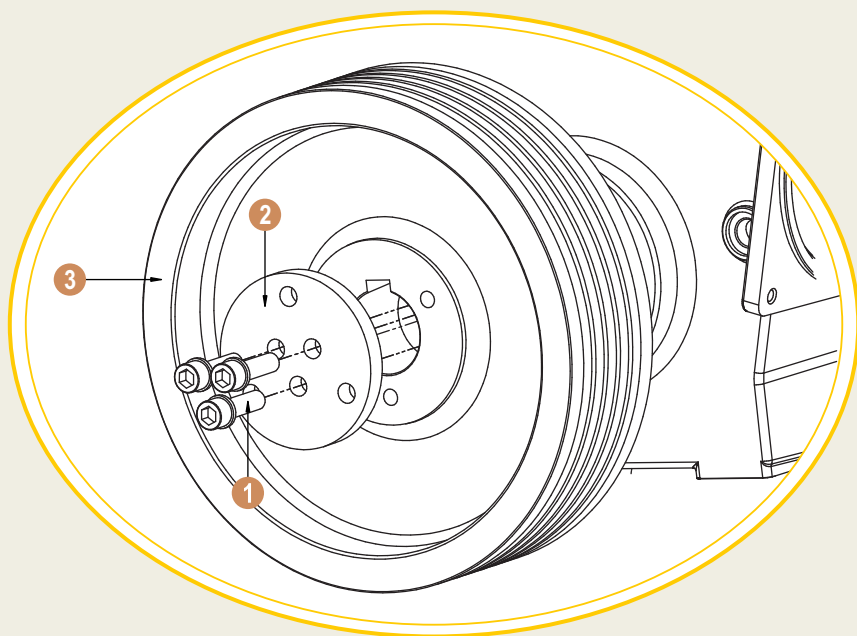

Fig No. 13

 **WARNING** **MAINTENANCE**

- Observe the safety at work regulations.
- The machine is allowed to be opened by qualified person only who have especially been trained with regard to this Traction Machine.
- Be aware of unusual running noises.
- To check brake wear and to check traction sheave.
- Make sure that the elevator can not be operated by any other person, other than the one who does the maintenance.
- Check the Parameters in Table No 3 at regular intervals.

Lift Machinery  **DANGER** use by Authorized Personnel only

Inspection intervals

Point To Be Consider	At initial Operation Resp. after 3 Months	After 6 Months	Every Year
Cleaning	✓	✓	✓
Lubrication		✓	✓
Backlash			✓
Brake Setting	✓	✓	✓
Brake Liner		✓	✓
Bearing			✓
Visual Check of the Screw Between Housing brake and traction sheave	✓	✓	✓
Check traction sheave if worn out		✓	✓

✓ - Indicates mandatory check by authorized technical person only.

Table No.03

MANUAL OPERATIONS IN CASE OF EMERGENCY

- Switch off the main switch in machine room.
- Firmly hold the flywheel **2** for the manual operation.
- Open the brake shoes **3** by acting on lever **1** and constantly exerting a sufficient force to open them. Move the flywheel **2** in the most suitable direction in order to take the cabin to the nearest floor and level with the reference mark on the steel ropes (where existing).
- Release the brake handle.

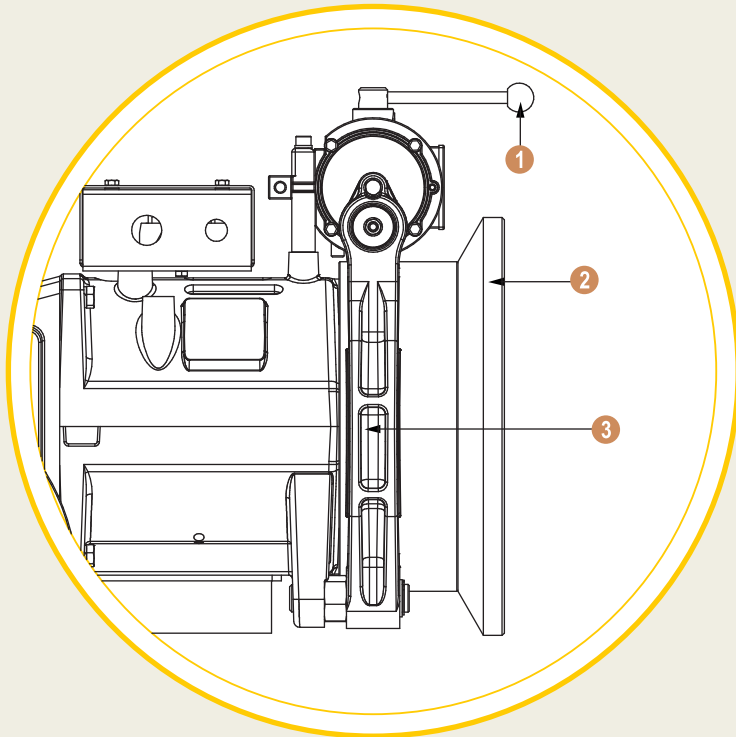

Fig No. 14



TROUBLE SHOOTING

FAULT	CAUSE	ROOT CAUSE
RUNNING NOISE	<ul style="list-style-type: none"> → Bearing Defective → VVVF - settings wrong → Encoder Defective 	<ul style="list-style-type: none"> → Contact Customer Service → Check VVVF- setting → Change Encoder
Excessive Temperature/ Temperature Protection /Trips	<ul style="list-style-type: none"> → Ambient Temperature Higher than 40° c → Applied Voltage is Lower than rated Voltage → Over Loaded → VVVF-settings Wrong 	<ul style="list-style-type: none"> → Enhance Shaft ventilation → Check Supplied Voltage → Control Load capacity → Check VVVF- setting
Motor will not start	<ul style="list-style-type: none"> → Motor Phases Connect Incorrect → VVVF-defective → Brake does not release 	<ul style="list-style-type: none"> → Check motor connection → Check VVVF- setting → See Brake faults
Brake does not release	<ul style="list-style-type: none"> → Power supply too low → Brake control wrong/defective → Brake Coil defective 	<ul style="list-style-type: none"> → Check power supply → Check brake wiring → Change brake

Table No. 04

DISPOSAL METHOD OF MACHINE AFTER CODDLE LIFE:

- All the parts in Machine are used as per latest environmental protection law, after the coddle life of this machine can be disposed off as follow.
- The Parts of Cast Iron, Steel, M.S, Bronze and copper can be reclaimed as a scrap, the insulated wire, plastic, electronic printed circuit board, corrugated paper wooden box etc may be disposed off as per National and local law of environment protection.

OPTIONAL ACCESSORIES

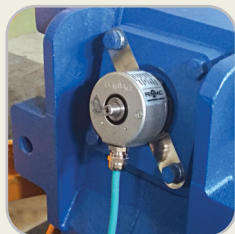

ENCODER ARRANGEMENT

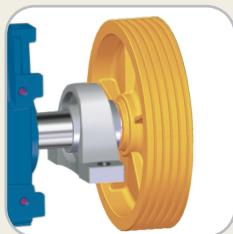

BASEMENT TRACTION MACHINE

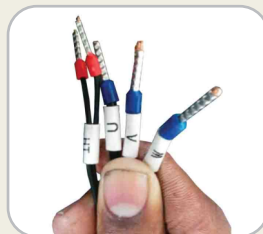

THERMAL PROTECTION
OF MOTOR

Spare parts & accessories which are not supplied by Sharp Engineers, Sharp Engineers will be in no way liable for any damage or destruction caused by the untested spares or accessories.

Customer Service Address

SHARP ENGINEERS

Plot no: - 552, Road-A Cross Road-12, G.I.D.C. Kathwada, Ahmedabad-382430

Fax No:- +91 - 79 -2290 1716 **E-mail :** service@sharpengineers.com

WARRANTY

1. Unless otherwise agreed upon in the sales contract, this warranty is governed by the following clauses:

1.1 The warranty on SHARP ENGINEERS products is valid for a period of One (1) year from the date shown on the shipping papers. During the warranty period, SHARP ENGINEERS will replace without charge an component that has been recognized as defective.

1.2 A component can be declared defective only if the relative defect has been recognized by SHARP ENGINEERS.

1.3 Components that are to be required or replace under warranty must be sent to SHARP ENGINEERS with all shipping and duty fees prepaid.

1.4 Request to SHARP ENGINEERS for service calls must be made by the customer in writing. labor, room and board, and travel costs must be paid for by the customer.

2. This warranty will automatically become null and void if any of the following circumstance occur:

2.1 The component for which warranty service has been requested has tampered with.

2.2 The machine has been used in any application which was not previously authorized by or agreed upon with SHARP ENGINEERS in writing.

2.3 The machine has been used in a way that does not confirm to the specification for which it has been built, as indicated in the Technical manual and in this operation and Maintenance manual.

2.4 The identification plates are missing, or it is impossible to identify the machine.

3. The following components, which are subjected to normal wear, are not included in this warranty: brake liners, bearings, electrical windings.

4. This warranty does not include compensation for shipping fees or down time.

5. Warranty claim procedure.

5.1 All warranty claims must be communicated to SHARP ENGINEERS in writing (or by fax) within 8 days from the day that the relative problem occurs.

5.2 SHARP ENGINEERS will conform in writing (or by fax) the eventual acceptance of proposed repairs to be executed by the customer will send its own technical personnel.

5.3 Any defective material replaced by the customer must remains at SHARP ENGINEERS disposition for 30 days so that the necessary verification can be performed; or, the material must be shipped to SHARP ENGINEERS when the company so requests in writing.

5.4 Absolutely no claims will be accepted for warranty repairs that were not previously authorized in writing by SHARP ENGINEERS.

5.5 In any case, a complete photographic study of the executed repairs operation must be supplied to SHARP ENGINEERS to correct the problem and improve the quality and reliability of its machines.

5.6 SHARP ENGINEERS reserves the right to ask back defective materials in order to check the cause of the problem. If defective materials don't reach SHARP ENGINEERS by 30 days from SHARP ENGINEERS request, the new part will be invoiced to the customer.

NOTE

A large rectangular area with a light beige background, containing horizontal dashed lines for writing notes.

NOTE

A large rectangular area with a light beige background and horizontal dashed lines, intended for handwritten notes.

**Global
Presence**



SHARP ENGINEERS

552, 'A' Road, Cross Road No - 12,
G.I.D.C., Kathwada, Ahmedabad - 382430,
Gujarat, INDIA.

Tele : + 91 79 2290 1711, 12, 14, 15.

E-mail : info@sharpengineers.com

sales@sharpengineers.com

Website : www.sharpengineers.com