

CAULDRON SERIES

| Geared Traction Machine |

CAULDRON[®]-125 N

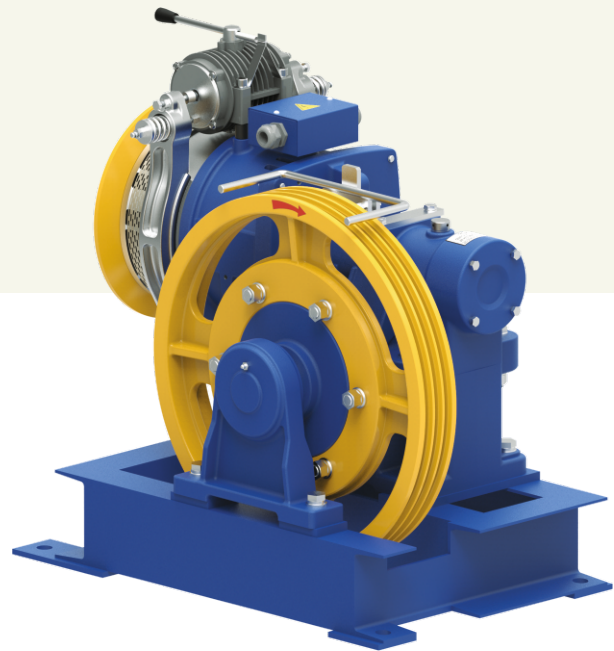

Static Load (kg)
3000



Gear Ratio
1/41



Oil Capacity (Ltr)
3.0



Brake Voltage (DC)
110V, 220V



Weight of Machine (kg)
238*

* Weight of machine is varies according to selection of sheave, Motor & Drive system.

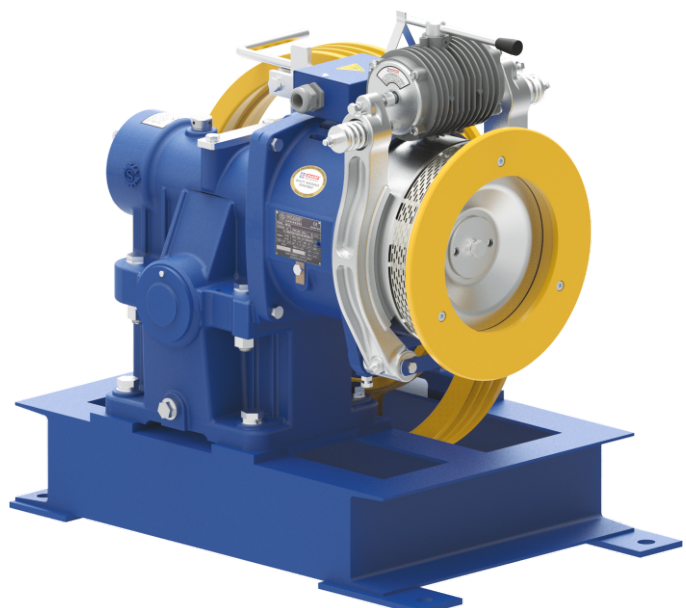

Geared Traction Machine



Listed loads don't include the rope's weight.
In order to know the net loads capacity, subtract rope's weight from the listed loads.

Position of the gearbox Up
Counter weight 50%
Plant efficiency 0.80

Machine	Duty Load		Roping	Async. Speed	Ratio	Motor Detail		RPM	Rated Current	Sheave Specification
	Person	Kg				(kw)	(HP)			
	(m/sec)	(kw)		(HP)	(A)	Sheave Dia x Rope Dia. X No. of Groove				
CAL - 125N	6	408	1:1	0.70	1/41	3.7	5.0	930	8.8	Ø 530 X 13mm X 3 Grv.
				1.00	1/41	4.5	6.0	1430	9.2	Ø 530 X 13mm X 3 Grv.
				1.00	1/41	5.5	7.5	1455	11.5	Ø 530 X 13mm X 3 Grv.

Kindly contact us for various speed and load combination

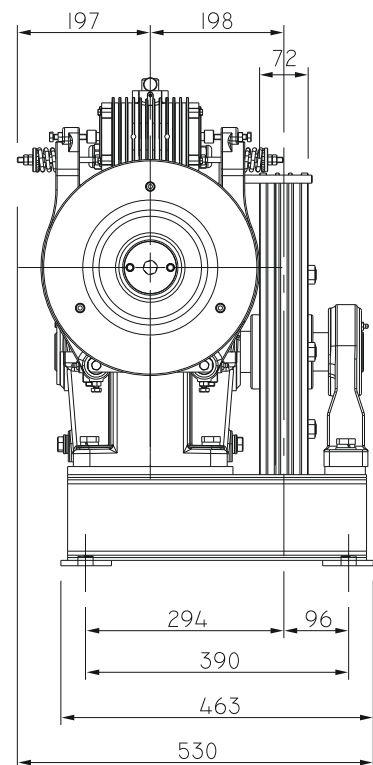
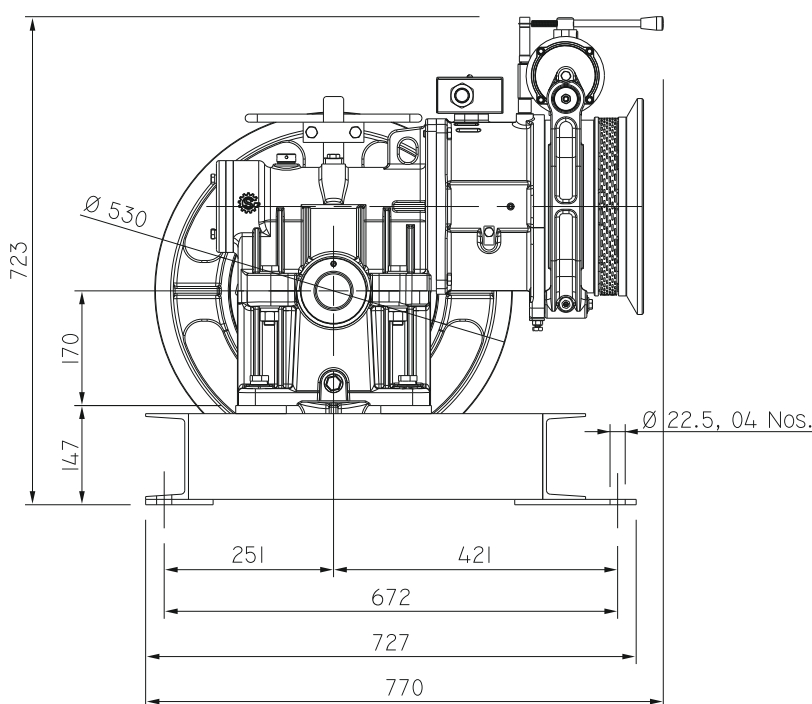

(All dimensions are in mm)