

MP SERIES

Geared Traction Machine

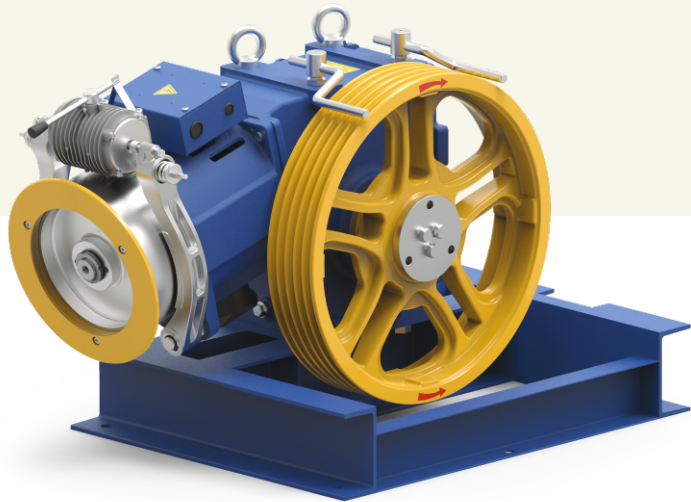

Static Load (kg)
3800



Gear Ratio
1/49, 1/59



Oil Capacity (Ltr)
4.5



Brake Voltage (DC)
110V, 220V



Weight of Machine (kg)
367*

* Weight of machine is varies according to selection of sheave, Motor.

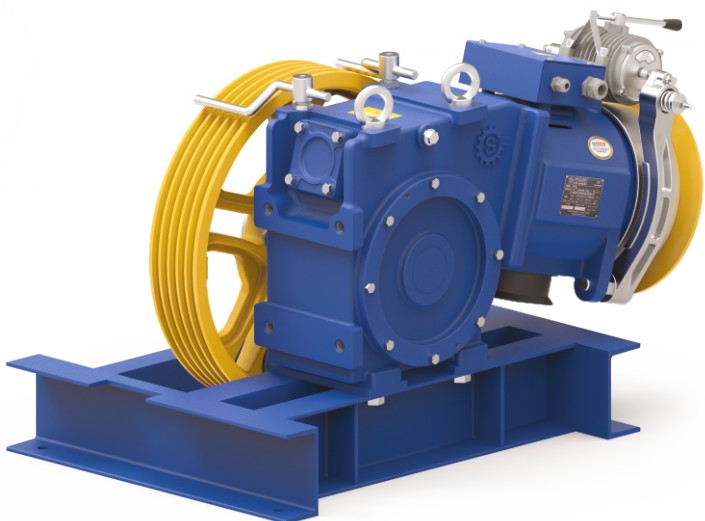

Geared Traction Machine



Listed loads don't include the rope's weight.
In order to know the net loads capacity, subtract rope's weight from the listed loads.

Position of the gearbox Up
Counter weight 50%
Plant efficiency 0.80

AC VVVF		400 V		50 Hz				Travelling : - 30 mtr		
Machine	Duty Load		Roping	Async. Speed	Ratio	Motor Detail		RPM (Async.)	Rated Current (A)	Sheave Specification
	Person	Kg		(m/sec)		(kw)	(HP)			Sheave Dia x Rope Dia. X No. of Groove
MM - 79	13	884	1:1	0.70	1/59	7.5	10.0	1423	14.5	Ø 560 X 13mm X 4 Grv.
				1.00	1/49	9.0	12.5	1458	20.5	Ø 600 X 13mm X 4 Grv.
	1500		2:1	0.32	1/59	6.7	9.0	1445	13.5	Ø 530 X 13mm X 4 Grv.
				0.50	1/49	7.5	10.0	1423	14.5	Ø 600 X 13mm X 4 Grv.

Kindly contact us for various speed and load combination

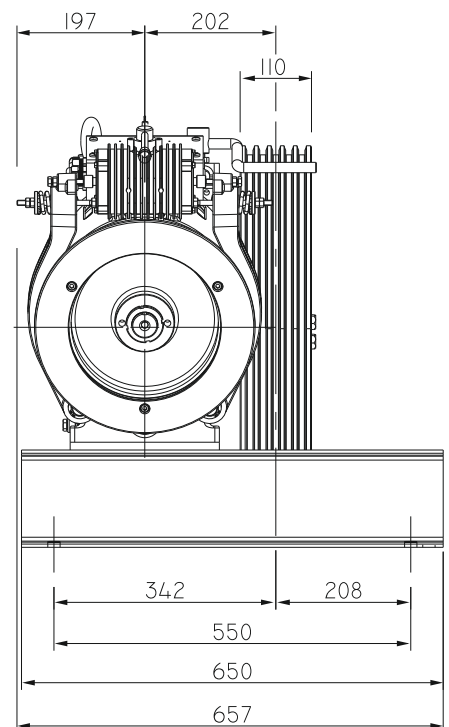
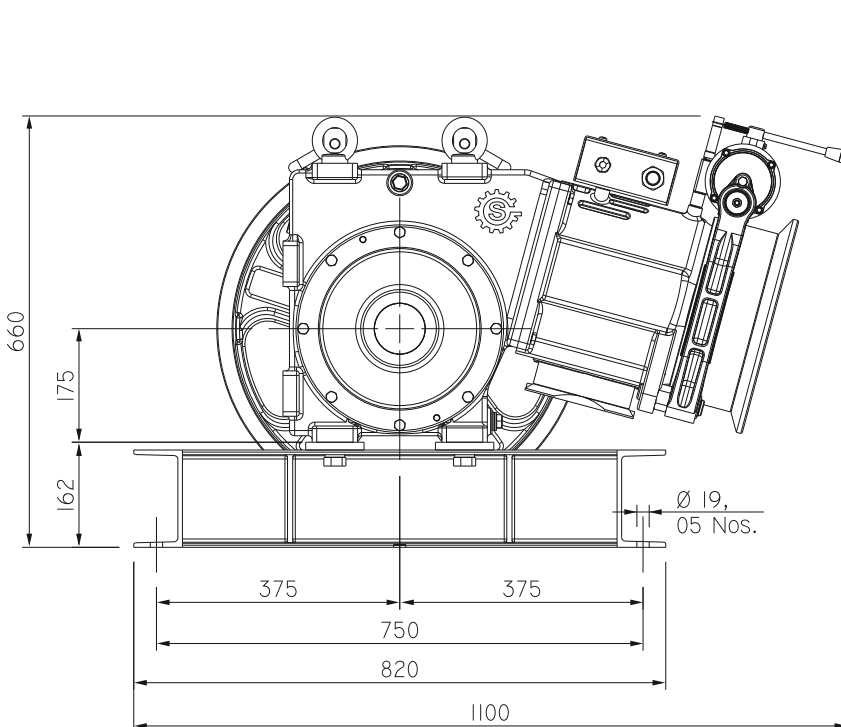

(All dimensions are in mm)