

SEG SERIES

Gearless Traction Machine

SEG-20S

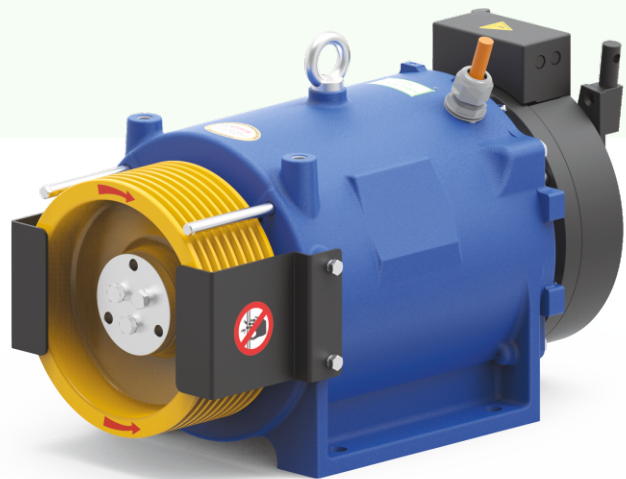

Voltage
400 V



Suspension
2:1



Brake
110 VDC



Max. Static Load
3400 Kg



Weight of Machine (kg)
162*

* Weight of machine is varies according to selection of sheave, Motor & Drive system.



Gearless Traction Machine

SEG-20S

| Specification | Load (kg) | Lift Speed (m/s) | Height (m) | Sheave Dia (mm) | No. of Groove X Rope Dia | Current (A) | Toque (Nm) | Rated Speed (rpm) | Frequency (Hz) | Power (kW) | Pole | Rating | INS Class. | IP Code |
|---------------|-----------|------------------|------------|-----------------|--------------------------|-------------|------------|-------------------|----------------|------------|------|----------|------------|---------|
| S20S-10P1A0 | 680 | 1.00 | ≤ 60 | Ø240 | 7 X Ø6.5 | 10.8 | 280 | 159 | 26.5 | 4.7 | 20 | S5 (40%) | F-Class | IP-40 |
| S20S-10P1A5 | | 1.50 | | | 7 X Ø6.5 | 14.5 | 280 | 239 | 39.8 | 7.0 | | | | |
| S20S-8P1B0 | 544 | 1.00 | ≤ 60 | Ø320 | 4 X Ø8.0 | 9.2 | 305 | 119 | 19.9 | 3.8 | 20 | S5 (40%) | F-Class | IP-40 |
| S20S-8P1B5 | | 1.50 | | | 5 X Ø8.0 | 12.2 | 305 | 179 | 29.8 | 5.7 | | | | |
| S20S-8P1B75 | | 1.75 | | | 5 X Ø8.0 | 16.5 | 305 | 209 | 34.8 | 6.7 | | | | |

Kindly contact us for various speed and load combination

| ØP | A | B | C | N X ØD | E | F | S |
|------|----|----|-----|----------|-----|-----|----|
| Ø240 | 97 | 56 | 111 | 7 X Ø6.5 | 572 | 320 | 11 |

| ØP | A | B | C | N X ØD | E | F | S |
|------|----|----|------|--------|-----|-----|----|
| Ø320 | 58 | 56 | 91.5 | 4 X Ø8 | 552 | 345 | 12 |
| Ø320 | 70 | 50 | 96.5 | 5 X Ø8 | 552 | 345 | 12 |

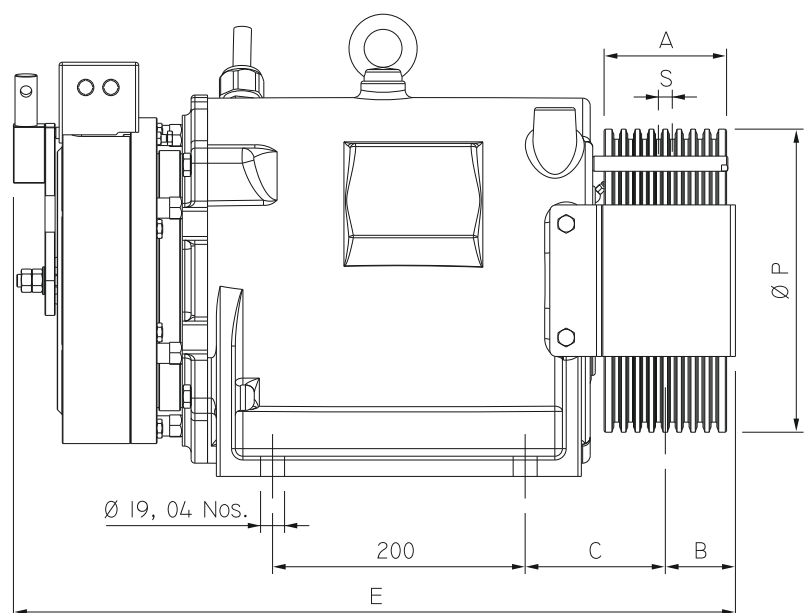
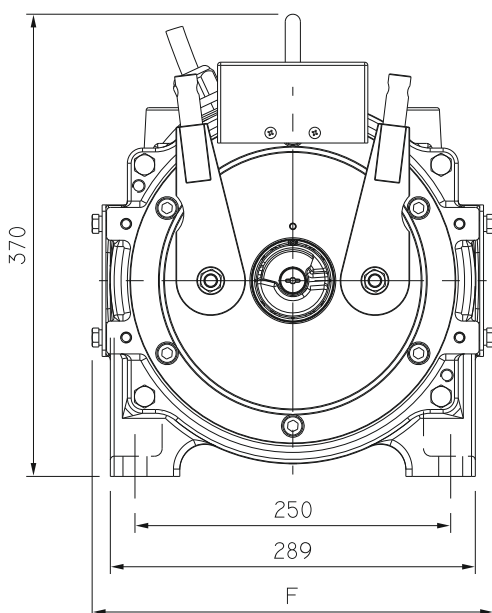

(All dimensions are in mm)