

SEG SERIES

Gearless Traction Machine

SEG-30S



Voltage
400 V



Suspension
2:1



Brake
110 VDC



Max. Static Load
3400 Kg



Weight of Machine (kg)
167*

* Weight of machine is varies according to selection of sheave, Motor & Drive system.

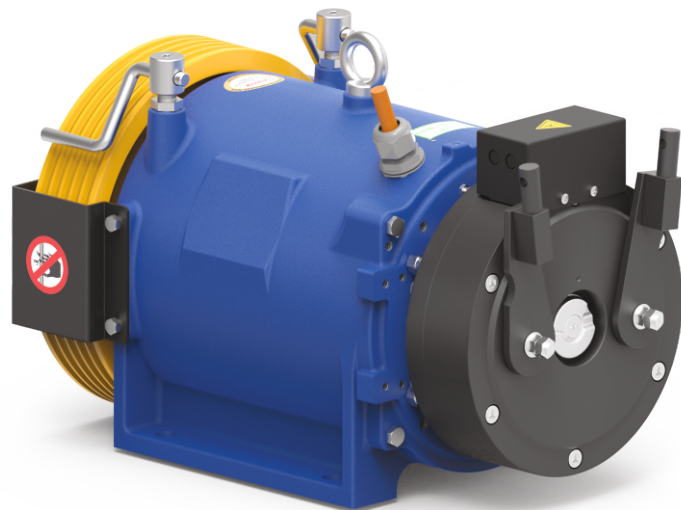

Gearless Traction Machine

SEG-30S

Specification	Load (kg)	Lift Speed (m/s)	Height (m)	Sheave Dia (mm)	No. of Groove X Rope Dia	Current (A)	Toque (Nm)	Rated Speed (rpm)	Frequency (Hz)	Power (kW)	Pole	Rating	INS Class.	IP Code
S30S-13P1A0	884	1.00	≤ 80	Ø240	8 X Ø6.5	15.0	350	159	26.5	5.8	20	S5 (40%)	F-Class	IP40
S30S-13P1A5		1.50			8 X Ø6.5	19.2	350	239	39.8	8.8				
S30S-10P1B0	680	1.00	≤ 80	Ø320	5 X Ø8.0	12.0	380	119	19.9	4.7	20	S5 (40%)	F-Class	IP40
S30S-10P1B5		1.50			6 X Ø8.0	16.5	380	179	29.8	7.0				
S30S-10P1B75		1.75			6 X Ø8.0	20.0	380	209	34.8	8.3				

Kindly contact us for various speed and load combination

ØP	A	B	C	N X ØD	E	F	S
Ø240	97	56	111	8 X Ø6.5	572	320	11

ØP	A	B	C	N X ØD	E	F	S
Ø320	70	50	96.5	5 X Ø8	552	345	12
Ø320	82	50	102.5	6 X Ø8	558	345	12

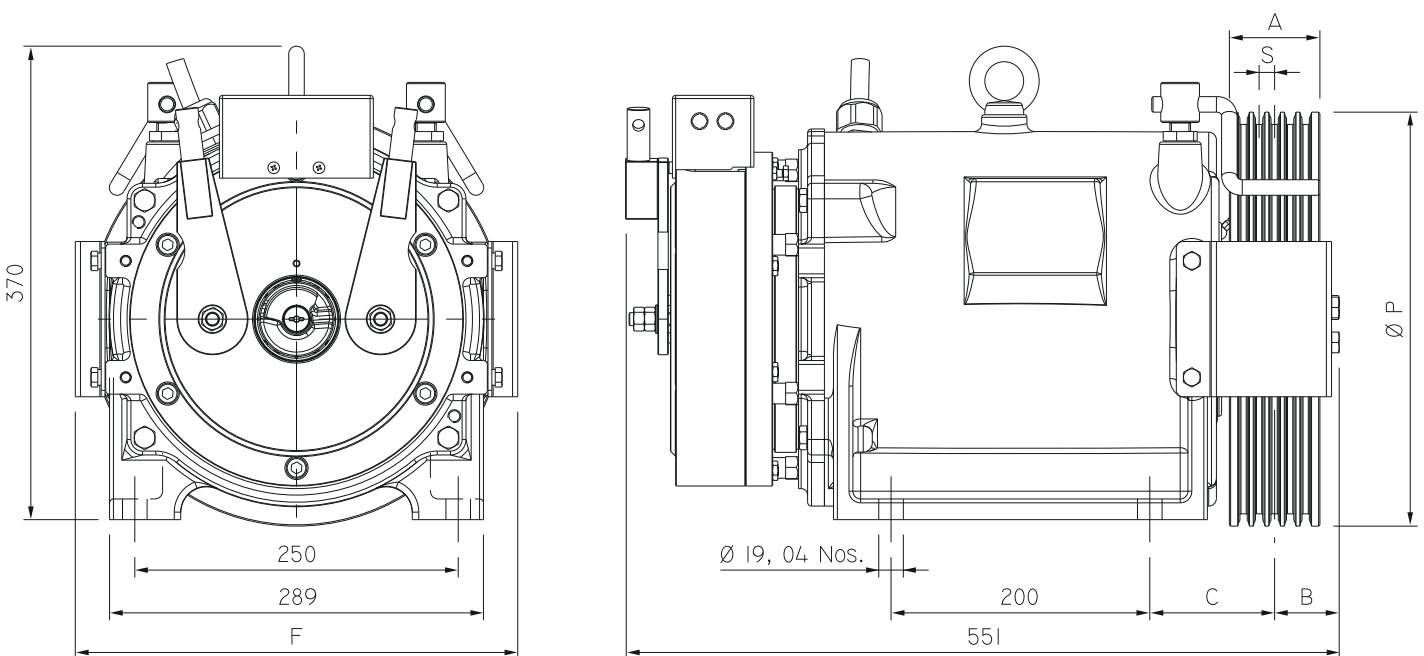

(All dimensions are in mm)