

# SEG SERIES

Gearless Traction Machine

**SEG-50S**



**Voltage**  
400 V



**Suspension**  
2:1



**Brake**  
110 VDC



**Max. Static Load**  
5500 Kg



**Weight of Machine (kg)**  
450\*

\* Weight of machine is varies according to selection of sheave, Motor & Drive system.



# Gearless Traction Machine



Specification	Load (kg)	Lift Speed (m/s)	Height (m)	Sheave Dia (mm)	No. of Groove X Rope Dia	Current (A)	Toque (Nm)	Rated Speed (rpm)	Frequency (Hz)	Power (kW)	Pole	Rating	INS Class.	IP Code
S50S-26P1A0	1768	1.00	≤ 80	Ø320	10 X Ø8.0	32.0	950	119	23.8	11.9	24	S5 (40%)	F-Class	IP40
S50S-26P1A5		1.50			10 X Ø8.0	36.0	950	179	35.8	17.8				
S50S-26P1A75		1.75			10 X Ø8.0	45.0	950	209	41.8	20.8				
S50S-2000P1A0	2000	1.00	≤ 80	Ø320	10 X Ø8.0	38.0	1080	119	23.8	13.4	24	S5 (40%)	F-Class	IP40
S50S-2000P1A5		1.50			10 X Ø8.0	43.0	1080	179	35.8	20.0				
S50S-2000P1A75		1.75			11 X Ø8.0	52.0	1080	209	41.8	23.8				
S50S-22P1B0	1500	1.00	≤ 80	Ø400	8 X Ø10.0	37.5	1030	96	19.1	10.2	24	S5 (40%)	F-Class	IP40
S50S-22P1B5		1.50			8 X Ø10.0	40.0	1030	143	28.6	15.3				
S50S-22P1B75		1.75			8 X Ø10.0	43.0	1030	167	33.4	18.0				

Kindly contact us for various speed and load combination

ØP	A	B	C	N X ØD	E	F	S
Ø400	136	78	178	7 X Ø10	720	426	16
				8 X Ø10			

ØP	A	B	C	N X ØD	E	F	S
Ø320	142	81	181	8 X Ø8	726	415	12
				10 X Ø8			
				11 X Ø8			

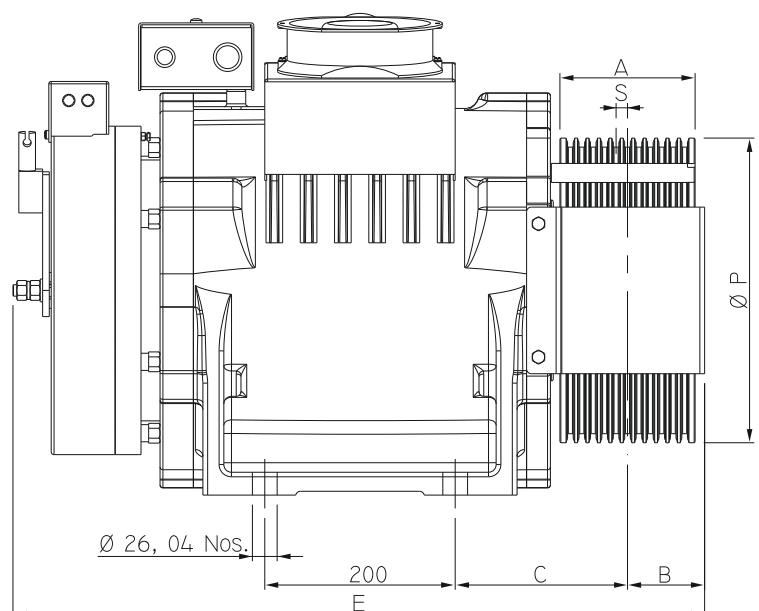
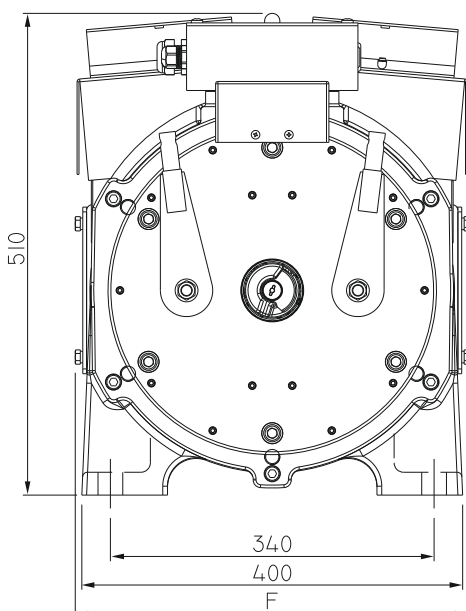

(All dimensions are in mm)