

# SEG SERIES

Gearless Traction Machine

**SEG-60S**



**Voltage**  
400 V



**Suspension**  
2:1



**Brake**  
110 VDC



**Max. Static Load**  
6500 Kg



**Weight of Machine (kg)**  
507\*

\* Weight of machine is varies according to selection of sheave, Motor & Drive system.



# Gearless Traction Machine

## SEG-60S

Specification	Load (kg)	Lift Speed (m/s)	Height (m)	Sheave Dia (mm)	No. of Groove X Rope Dia	Current (A)	Toque (Nm)	Rated Speed (rpm)	Frequency (Hz)	Power (kW)	Pole	Rating	INS Class.	IP Code
S60S-2500P1A0	2500	1.00	≤ 80	Ø320	11 X Ø8.0	42.0	1330	119	23.8	16.6	24	S5 (40%)	F-Class	IP-40
S60S-2500P1A5		1.50			11 X Ø8.0	52.0	1330	179	35.8	25.0				
S60S-2000P1B0	2000	1.00	≤ 80	Ø400	8 X Ø10.0	47.0	1350	96	19.1	13.5	24	S5 (40%)	F-Class	IP-40
S60S-2000P1B5		1.50			8 X Ø10.0	51.0	1350	143	28.6	20.2				
S60S-2000P1B75		1.75			8 X Ø10.0	53.0	1350	167	33.4	23.7				
S65S-3000P0A5	3000	0.50	≤ 80	Ø320	11 X Ø8.0	30.0	1590	60	10.0	10.0	24	S5 (40%)	F-Class	IP-40
S65S-3000P1A0		1.00			11 X Ø8.0	51.0	1590	119	23.8	16.6				

Kindly contact us for various speed and load combination

ØP	A	B	C	N X ØD	E	F	S
Ø400	136	78	178	8 X Ø10	823	426	16

ØP	A	B	C	N X ØD	E	F	S
Ø320	142	81	181	10 X Ø8	829	415	12
				11 X Ø8			

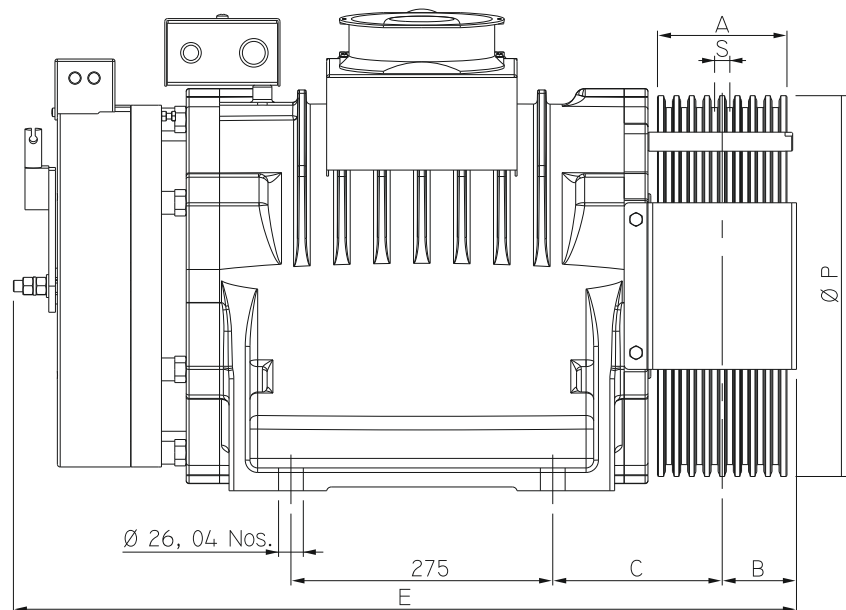
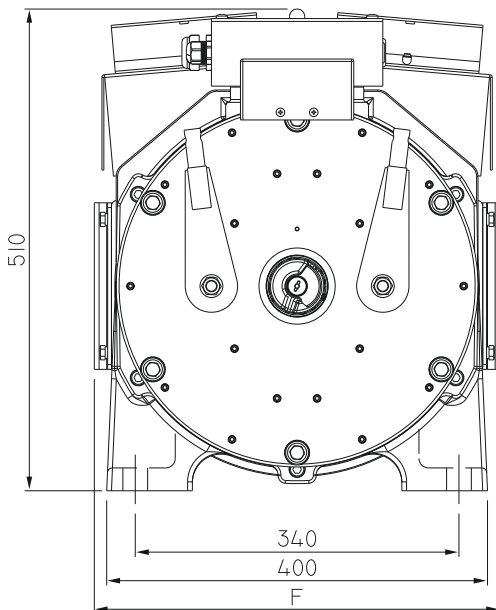

(All dimensions are in mm)