

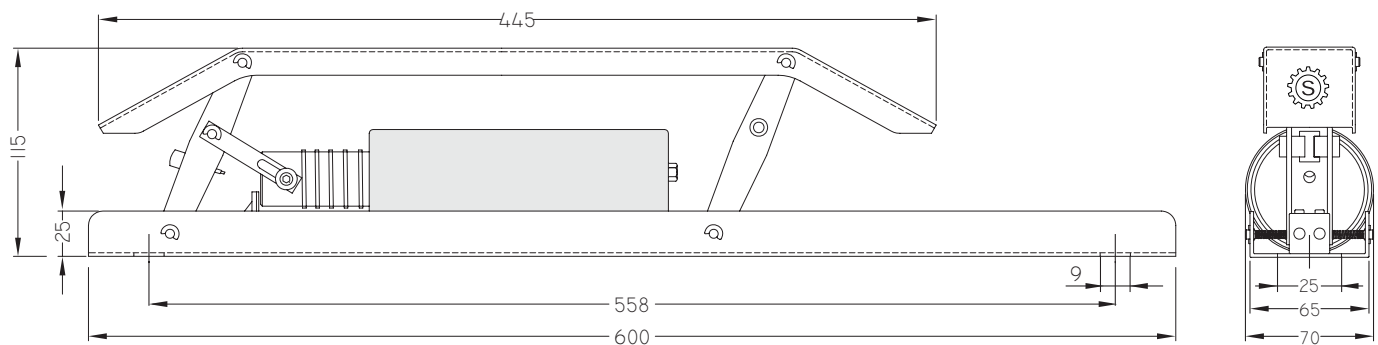

Features :

- Noise Less.
- Maintenance Free.
- Compact Design & Smart Look.
- Easy Installation
- Available in 110V / 220V.
- It Works in Pneumatic Principle.
- It's Working Pressure can be Adjustable.



All dimensions are in mm.

Subject to change without any prior notice!