

THE INFORMATION CONTAINED IN THIS DRAWING IS THE ONLY PROPERTY OF SHARP ENGINEERS
 ANY REPRODUCTION IN PART OR AS WHOLE WITHOUT THE WRITTEN PERMISSION OF SHARP
 ENGINEERS IS PROHIBITED.

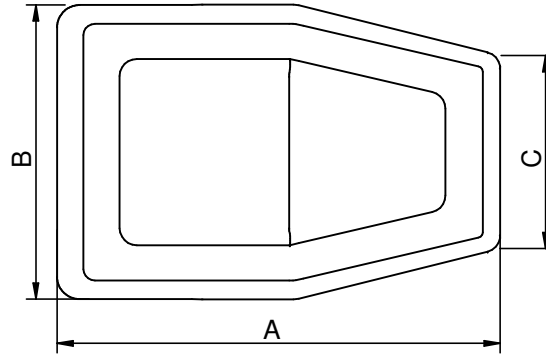
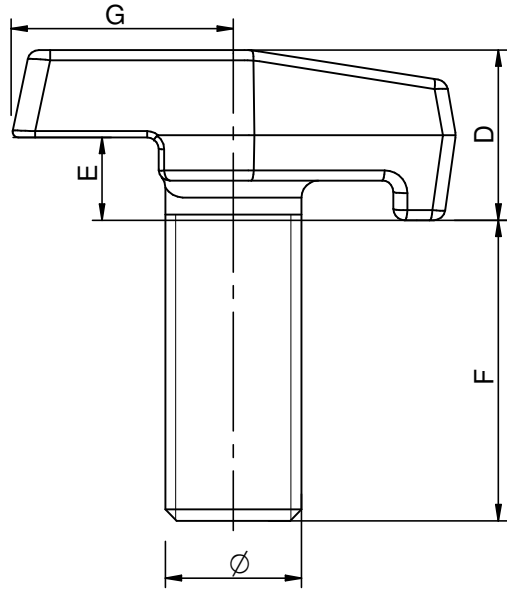

GUIDE CLIP							
Ø	A	B	C	D	E	F	G
mm	mm	mm	mm	mm	mm	mm	mm
	±1.3	±1.3	±1.3	±1	±0.5	±1.3	±1.3
M10	32	23	15	13	5.5	22.5	16
M12	39	26	17	15	7.3	26.5	19.5
M14	45	29	17	18.5	9.5	36	21
M16	50	34	17	20	10.5	40	23.5

REVISION No.

DESCRIPTION

DATE

APPROVED BY

DRWN BY
ANKIT PATEL
DRWN DATE
14/07/2022

SIZE
A4

SCALE

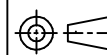

TITLE:-

GUIDE CLIP
G.A.DRAWING

