

# GEARED TRACTION MACHINE

**LIDER**  
Flame Proof

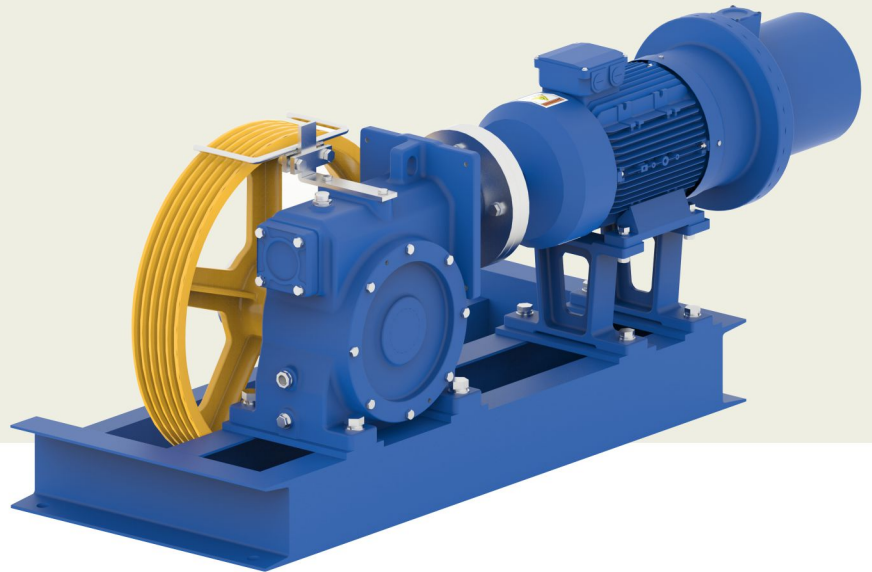

Static Load (kg)  
3800



Duty Load (kg)  
1500



Gear Ratio  
1/49

Max. Allow Weight  
Car + Car Frame  
+ Operator  
1000 (kg)



Oil Capacity (Ltr)  
3.5



Weight of Machine (kg)  
481\* (With Bed Plate)\*

\* Weight of machine is varies  
according to selection of  
sheave, Motor & Drive system.

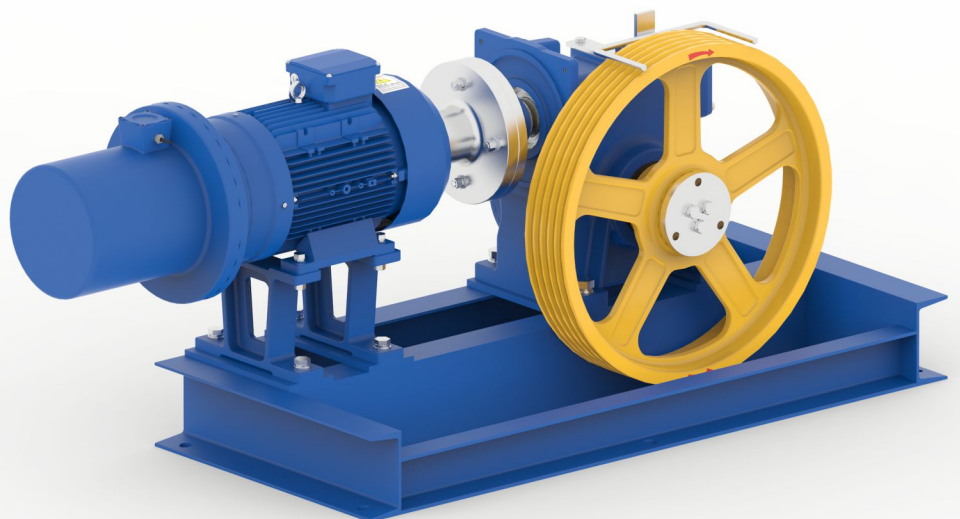

# GEARED

## TRACTION MACHINE

**LIDER**  
Flame Proof

Roping 2:1 | Travelling : 15 mtr

Machine	Duty Load	Async. Speed	Gear Ratio	Motor Detail		RPM	Rated Current	Sheave Specification	Max. Allow Weight (Car + Car Frame + Operator)
	(Kg)	(m/sec)		(kw)	(HP)				
LIDER	1500	0.5	1/49	7.5	10.0	1440	16.0	Ø600 X 13mm X 4 Grv	1000

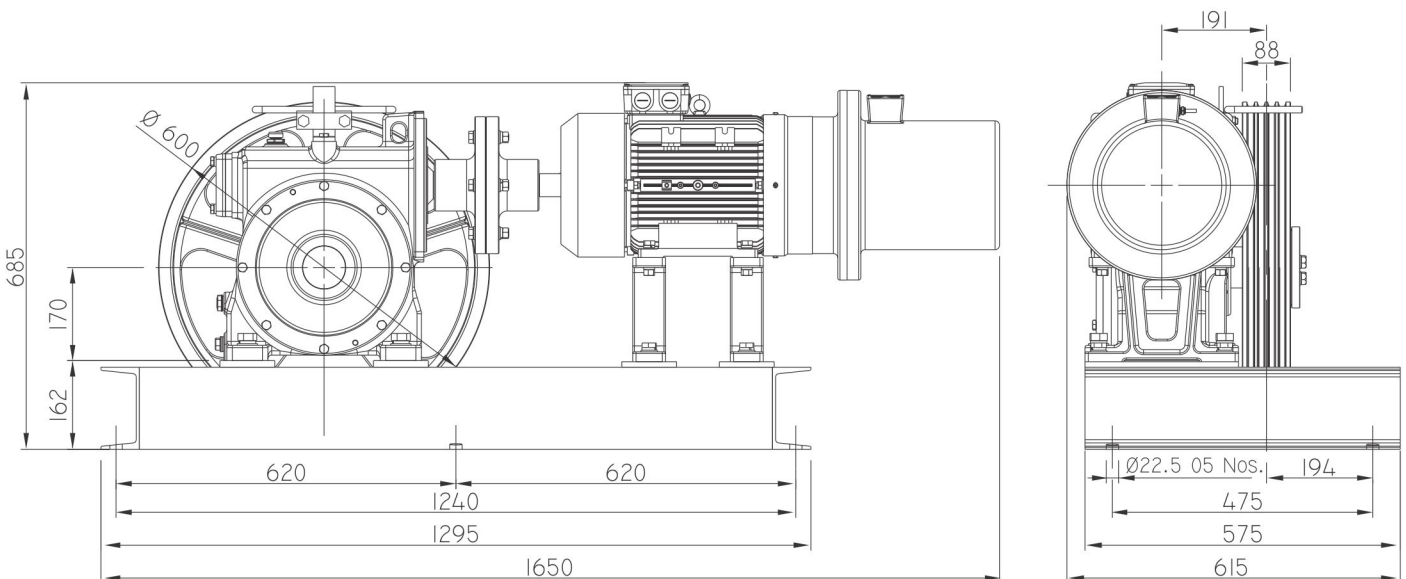

(All dimensions are in mm)

Subject to change without any prior notice!