

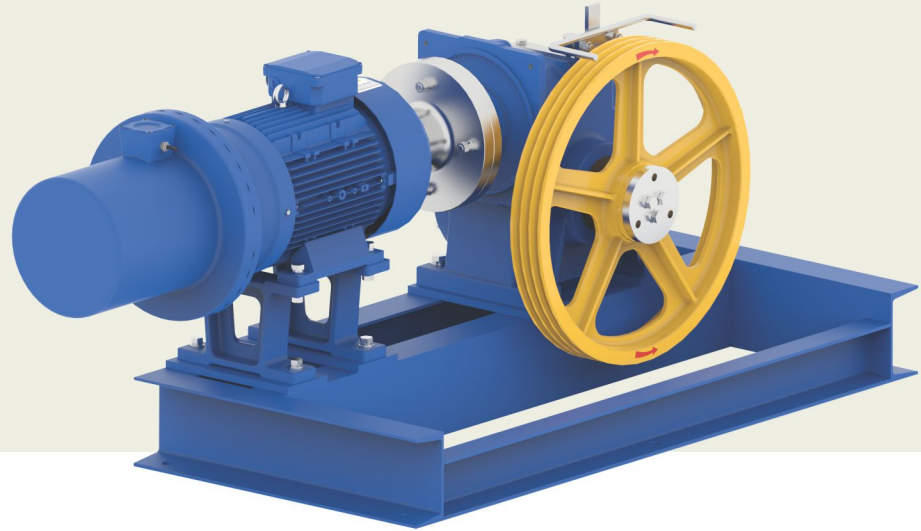

GEARED TRACTION MACHINE

totus
Flame Proof



Static Load (kg)
3200



Duty Load (kg)
1000



Gear Ratio
1/37

Max. Allow Weight
Car + Car Frame
+ Operator
850 (kg)



Oil Capacity (Ltr)
3.5



Weight of Machine (kg)
448* (With Bed Plate)*

* Weight of machine is varies
according to selection of
sheave, Motor & Drive system.

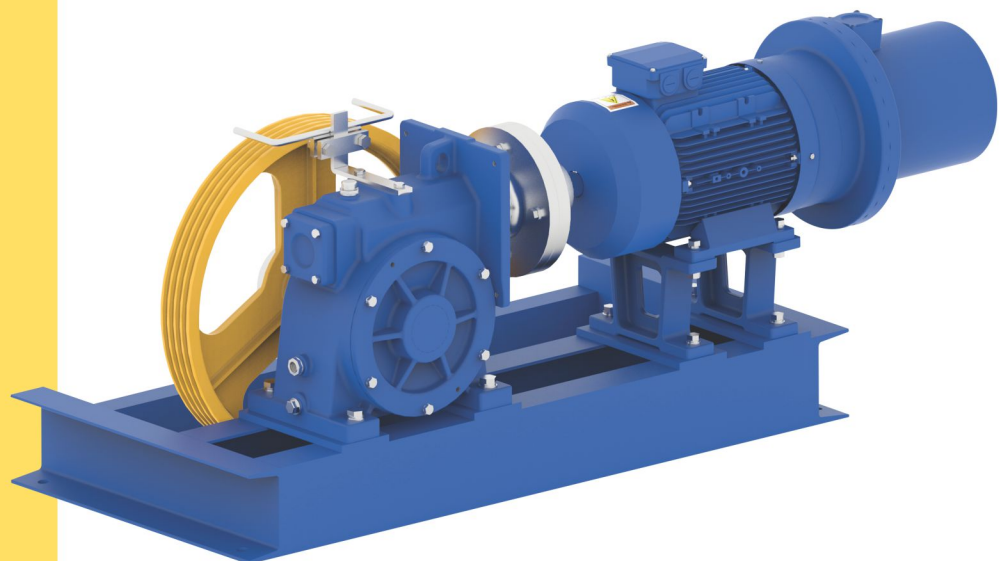

GEARED

TRACTION MACHINE

totus
Flame Proof

Roping 2:1 | Travelling : 15 mtr

Machine	Duty Load	Async. Speed	Gear Ratio	Motor Detail		RPM	Rated Current	Sheave Specification	Max. Allow Weight (Car + Car Frame + Operator)
	(Kg)	(m/sec)		(kw)	(HP)			Sheave Dia X Rope Dia X No. of Groove	(Kg)
TOTUS	1000	0.5	1/37	5.5	7.5	1440	12.0	Ø530 X 13mm X 3 Grv	850

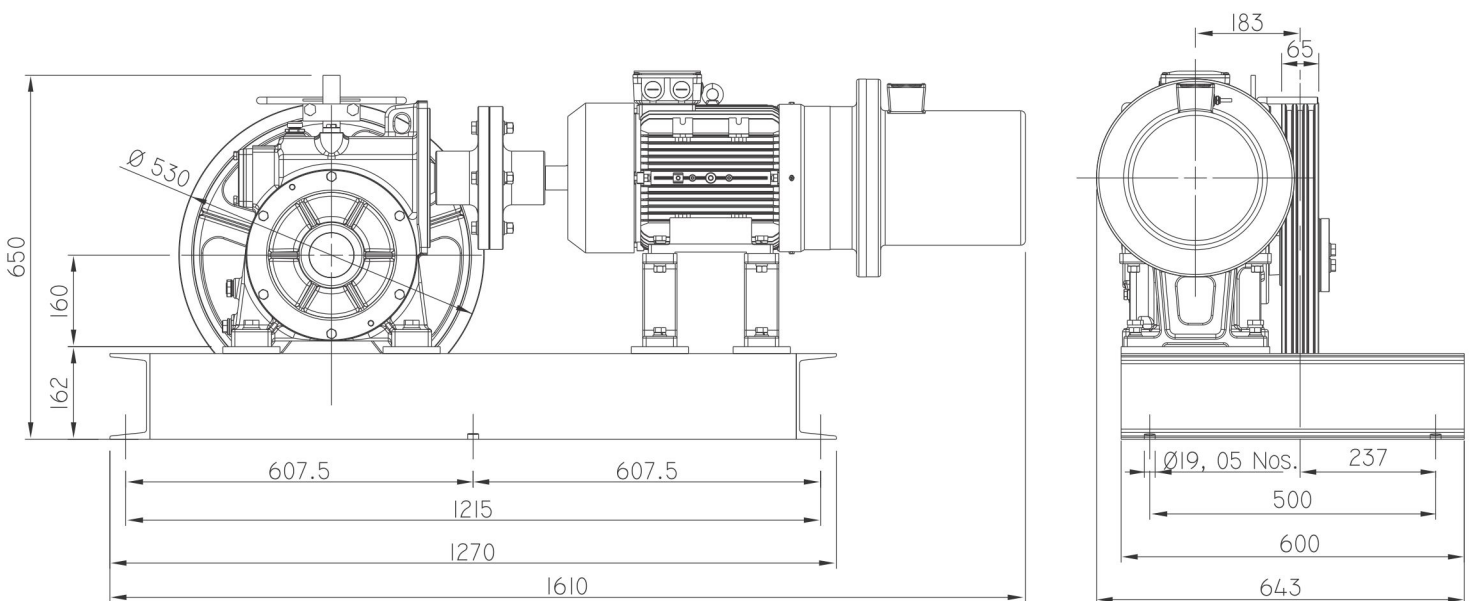

(All dimensions are in mm)