

tusker
Flame Proof

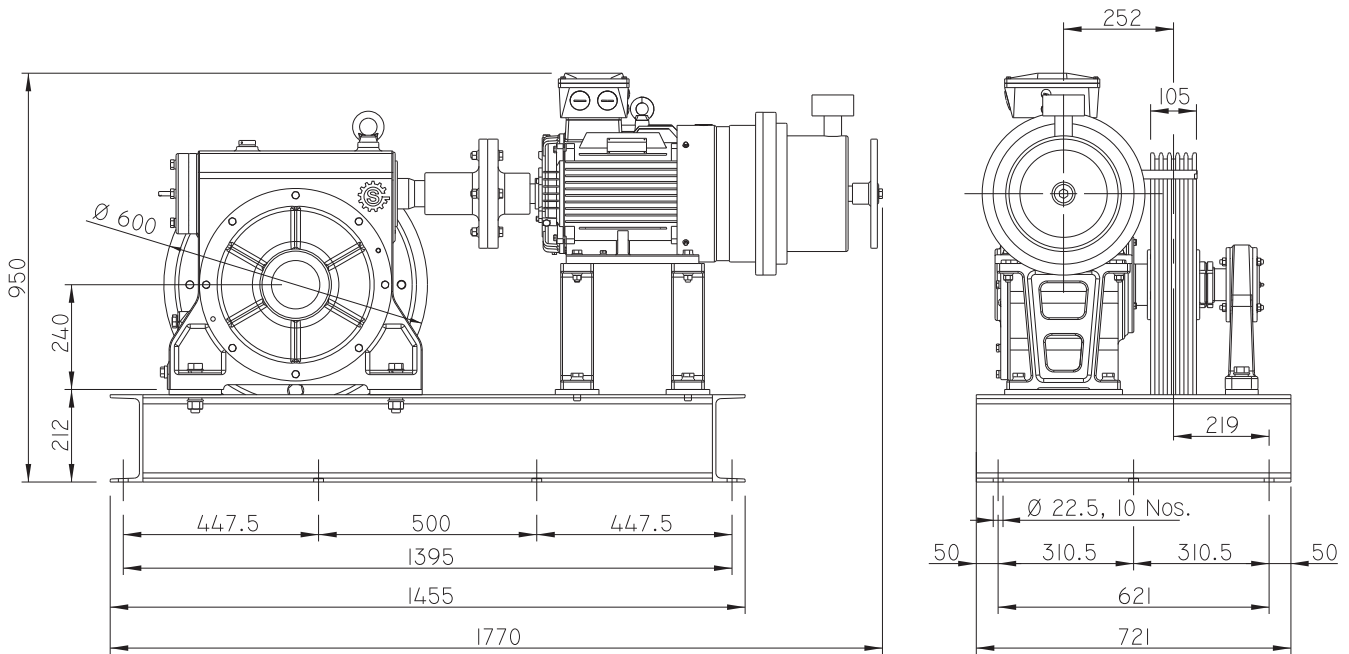
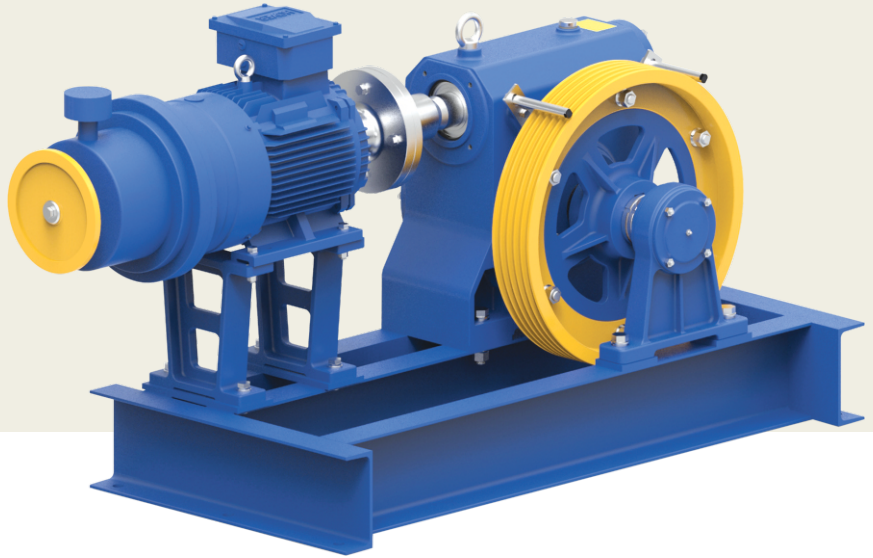

(All dimensions are in mm)

Roping 2:1 | Travelling : 15 mtr

Machine	Duty Load	Async. Speed	Gear Ratio	Motor Detail		RPM	Rated Current	Sheave Specification	Max. Allow Weight (Car + Car Frame + Operator)
	(Kg)	(m/sec)		(kw)	(HP)			(Async.)	(A)
Tusker	2500	0.5	1/46	14.5	20.0	1455	31.0	Ø600 X 13mm X 5 Grv	1500
	3000	0.5	1/46	14.5	20.0	1455	31.0	Ø600 X 13mm X 5 Grv	2000