

# MP SERIES

Geared Traction Machine

BISSON™

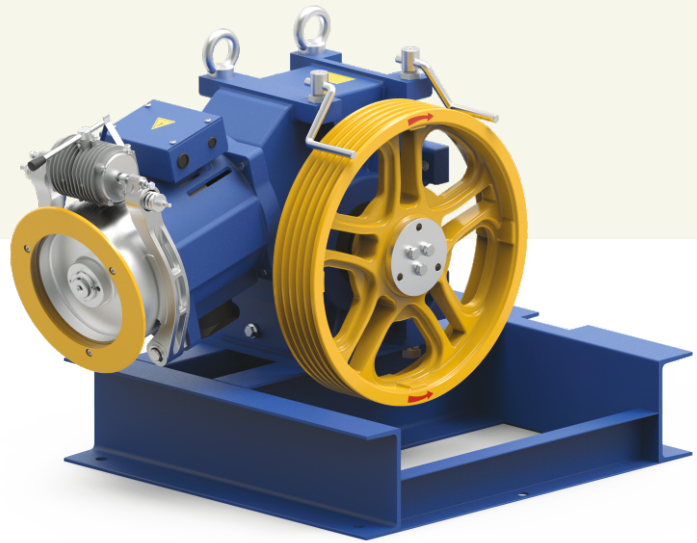

**Static Load (kg)**  
4400



**Gear Ratio**  
1/46



**Oil Capacity (Ltr)**  
6.0



**Brake Voltage (DC)**  
110V, 220V



**Weight of Machine (kg)**  
461\*

\* Weight of machine is varies according to selection of sheave, Motor.

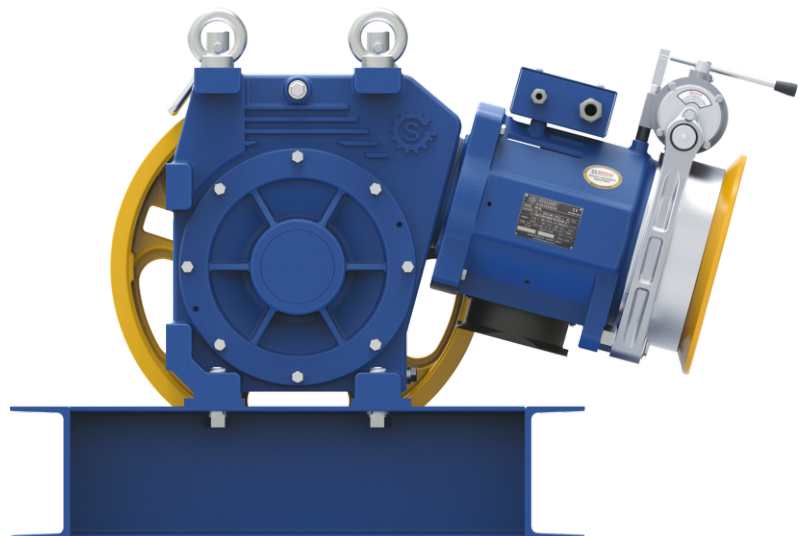

# Geared Traction Machine



Listed loads don't include the rope's weight.  
In order to know the net loads capacity, subtract rope's weight from the listed loads.

Position of the gearbox Up  
Counter weight 50%  
Plant efficiency 0.80

Machine	Duty Load		Roping	Async. Speed (m/sec)	Ratio	Motor Detail		RPM (Async.)	Rated Current (A)	Sheave Specification Sheave Dia x Rope Dia. X No. of Groove
	Person	Kg				kw	(HP)			
	BISON	16		1088	1:1	1.00	1/46	11.0	15.0	1445
	2000		2:1	0.50	1/46	11.0	15.0	1440	22.0	Ø 600 X 13mm X 4 Grv.

Kindly contact us for various speed and load combination

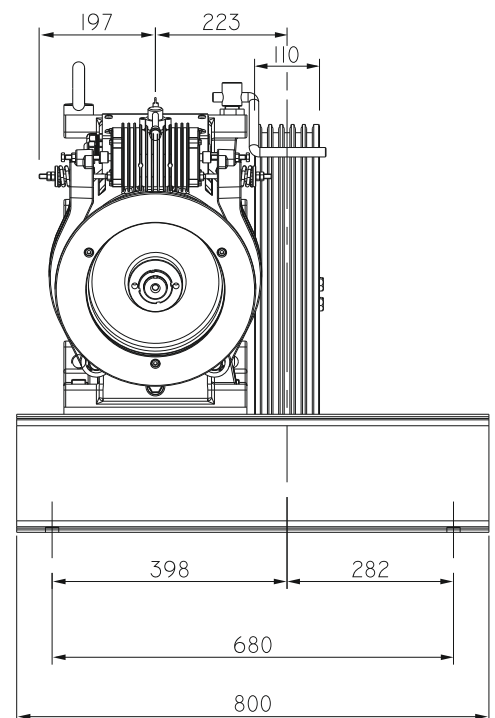
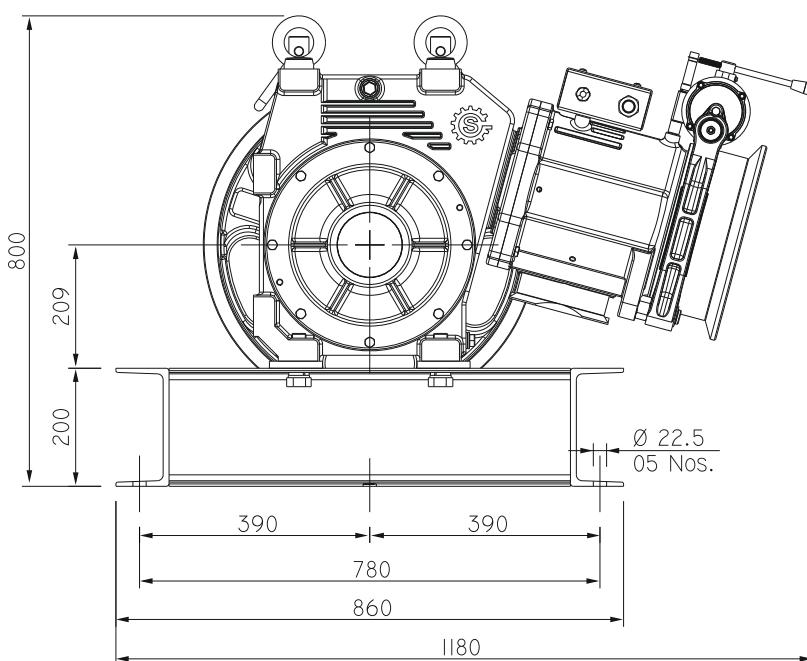

(All dimensions are in mm)