

# MP SERIES

Geared Traction Machine

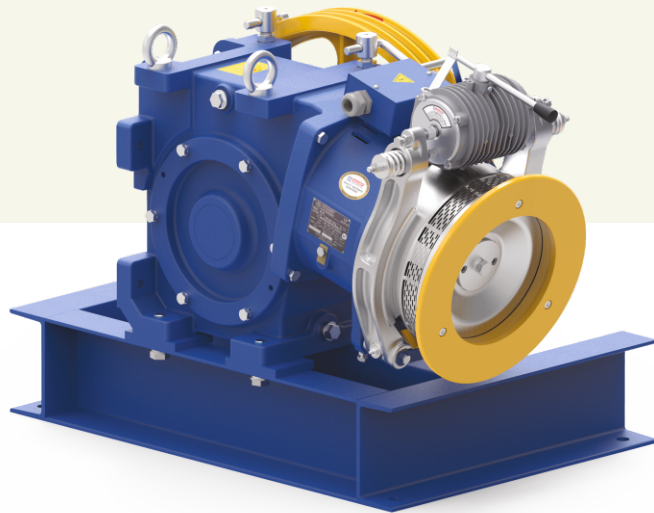

**Static Load (kg)**  
3000



**Gear Ratio**  
1/41



**Oil Capacity (Ltr)**  
3.0



**Brake Voltage (DC)**  
110V, 220V



**Weight of Machine (kg)**  
222\*

\* Weight of machine is varies according to selection of sheave, Motor.

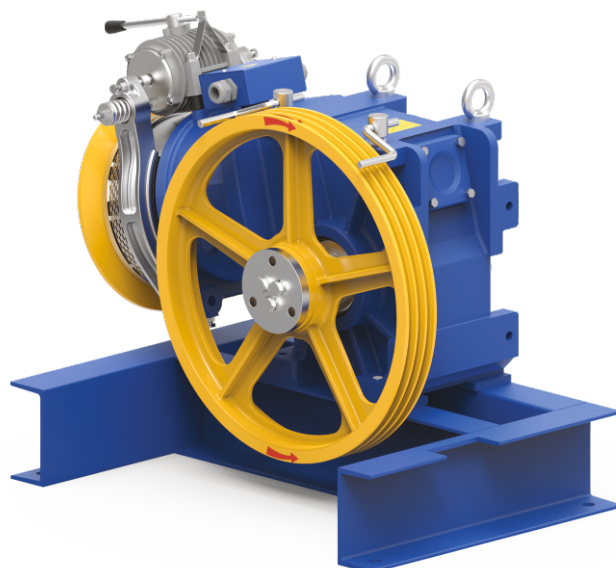

# Geared Traction Machine



Listed loads don't include the rope's weight.  
In order to know the net loads capacity, subtract rope's weight from the listed loads.

Position of the gearbox Up  
Counter weight 50%  
Plant efficiency 0.80

AC VVVF		400 V		50 Hz				Travelling : - 30 mtr		
Machine	Duty Load		Roping	Async. Speed	Ratio	Motor Detail		RPM	Rated Current	Sheave Specification
	Person	Kg		(m/sec)		(kw)	(HP)			(Async.)
MP-61	6	408	1:1	0.70	1/41	3.7	5.0	930	8.8	Ø 530 x 13mm x 3 Grv
				1.00		4.5	6.0	1430	9.2	Ø 530 x 13mm x 3 Grv

Kindly contact us for various speed and load combination

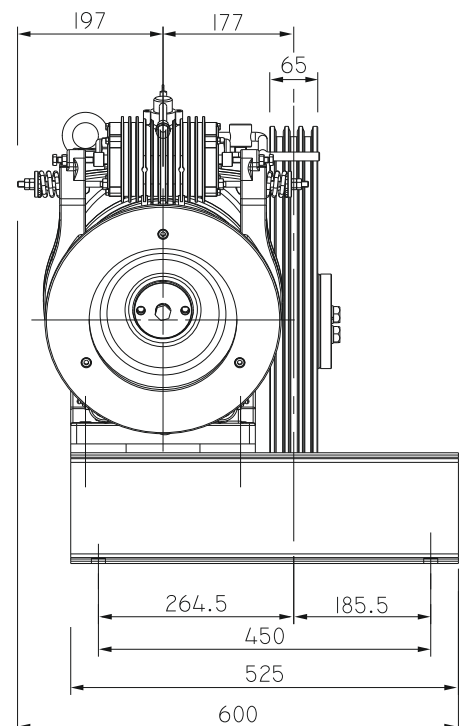
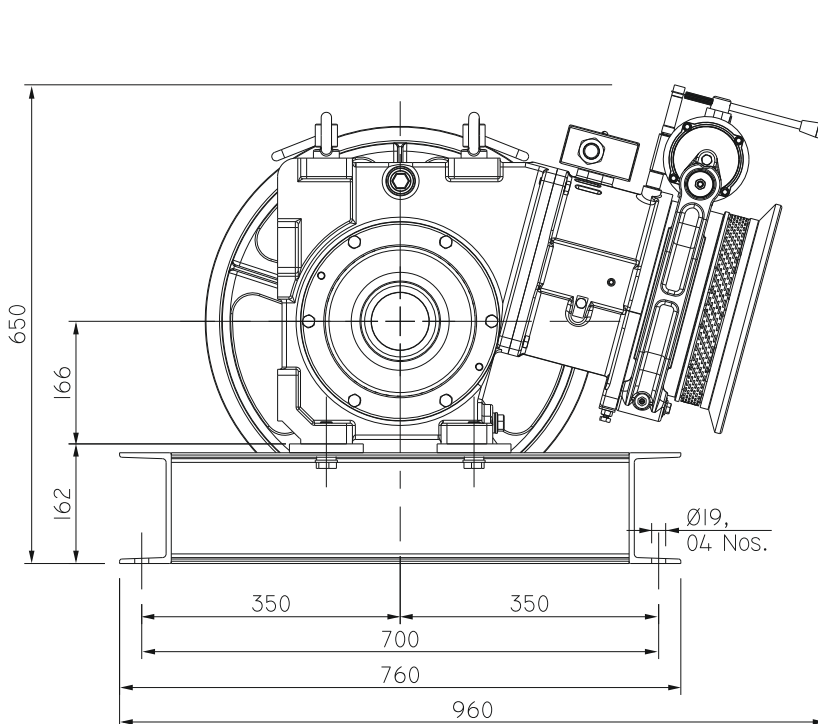

(All dimensions are in mm)