



USER'S GUIDE

SEG Series

G

EARLESS

Traction Machine



The **Quality** Inspires Trust



WARRANTY CERTIFICATE

OWNER DETAILS

Customer Name:

Address:

.....

City:

State:

Pin Code:

Country:

Telephone No:

Cell No:

E-Mail ID:

MACHINE DETAILS

Model No:

Machine Serial No:

Warranty Start Date:

Warranty Expiry Date:

Agent:

Sr. No.	Description	Page No.
01	General Information.....	03
	1.1 General Instructions	
	1.2 Use of Gearless Lift Machine	
	1.3 Safety Instructions & Symbols.	
	1.4 Copy Write	
02	Technical Drawing.....	04-15
03	Machine Identification with Machine Name - Plate.....	16
04	Safety Precaution	17
05	Transport & Storage	18
06	Commissioning	19
07	Electric Connection	20-23
	7.1 - Motor Connection	
	7.2 - Brake Connection	
	7.3 - Brake Micro Switch	
08	Thermal Protection of Motor	24
09	Over Excitation Switch (Rectifier Switch) Connection.....	24
10	Encoder Connection (Encoder ERN - 1387)	25
11	Maintenance.....	26
12	How to Replace Sheave.....	27
13	How to Disassemble and Assemble Encoder.....	28
14	Manual Brake Operating Attachment.....	29
	14.1 - Manual Operation in Case of Emergency - For SEG Series	
	14.2 - Manual Operation in Case of Emergency - For SEW Series	
15	Optional Emergency Rescue Device	30
16	Trouble Shooting.....	31
17	Warranty.....	32-33

01 - GENERAL INFORMATION

1.1. General instructions :-



This Manual is part of the drive and must always be kept in its vicinity for reference at all the times. All persons involved in installation, operation, maintenance or repair of the drive must have read and understood this manual. Sharp Engineers takes no responsibility for damage or disruption caused by disregard of this manual.

1.2. Use of Gearless Lift Machine :-





Traction machines are not Ready-to-use products and May only be Operated after having been installed with other incorporated parts/spares/ Machines or plants and established with their Protective grating, barriers, constructive Devices provides as per respective E U Directives and national and local Law.

1.3. Safety Instructions & Symbols :-



- Before Using the Gearless Machine , read these "Precautions" thoroughly and operate in the correct way.
- The instructions in this section all relate to safety; be sure to maintain safe operation conditions.
- "Danger", "Warning" and "caution" have the following meanings in these instructions.

 DANGER	This make indicates procedures which, if improperly performed, are most likely to result in the death of serious injury to the users or service personnel
 WARNING	This make indicates procedures which, if improperly performed, might lead to the death or serious injury of the users
 CAUTION	This make indicates procedures which, if improperly performed, might possibly results in personal harm to the users, Or Damage to property.

- SEG - 05, SEG - 10, SEG - 20, SEG - 30, SEG - 40, SEG - 50, SEG - 60, SEG - 70, SEW - 10, SEW - 20 & SEG - β1. Gearless lift machines are not ready to use product, They may only be operated after they have been installed in lift system and their safe operation has been ensured by taking the appropriate measurement.
- Only qualified personnel are authorised to perform installation work or maintenance work, and this must be done in accordance with the relevant instructions. The personnel must be familiar with the installation, maintenance for the machine.

1.4. Copy Write :-

The copyright to this manual is held by Sharp Engineers, G.I.D.C. Kathwada, Ahmedabad-382430. Gujarat. India.

This manual must not be wholly or partly reproduced for competitive purposes, used in any unauthorized way or made available to third parties without our agreement.

SEG-05S

FOR HOME LIFT

For Sharp Brake

Technical Drawing

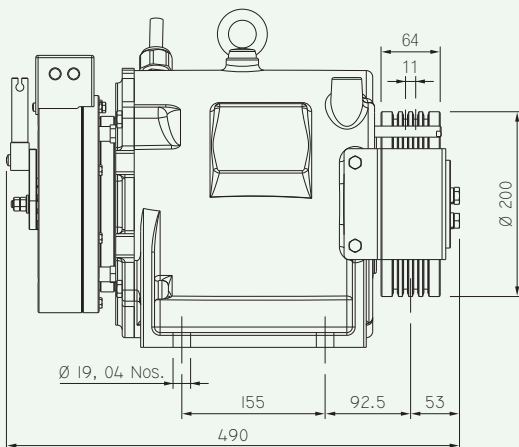
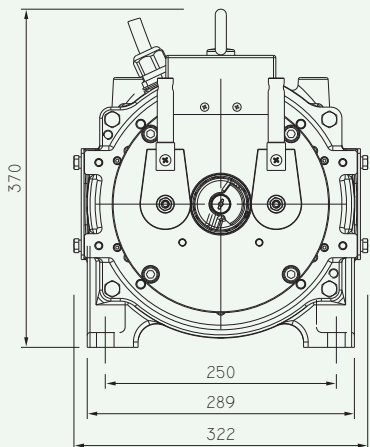

Weight of Machine (kg) : 117*

For Mayr Brake

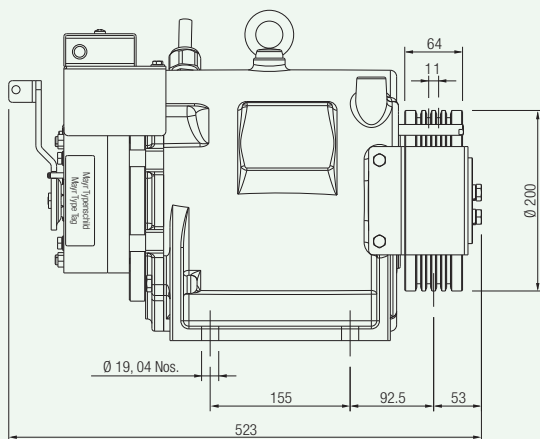
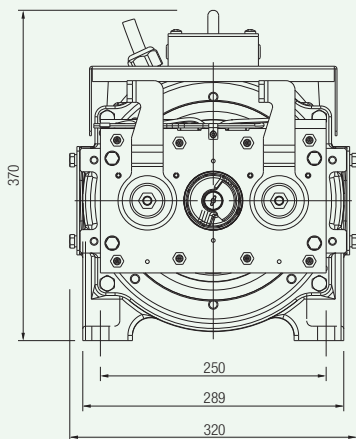

Weight of Machine (kg) : 117*

* Wight of machine is varies according to selection of sheave, motor & brake.

Subject to change without any prior notice !
All dimension are in mm.

SEG-10S

For Sharp Brake

Technical Drawing

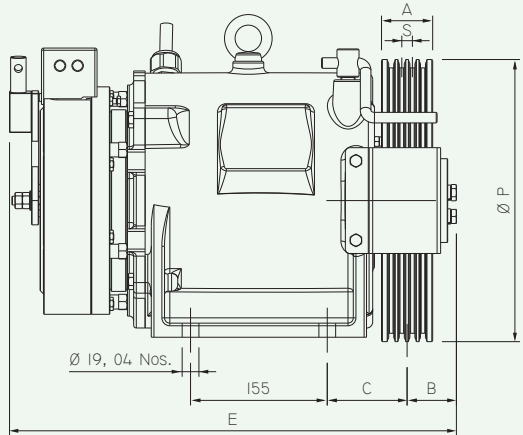
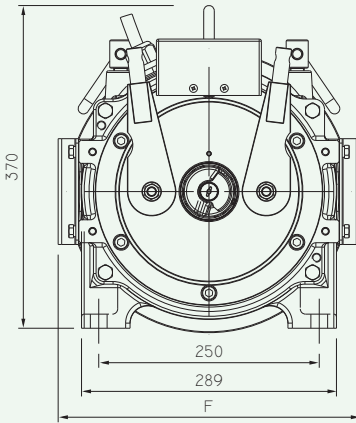

Weight of Machine (kg) : 139*

For Mayr Brake

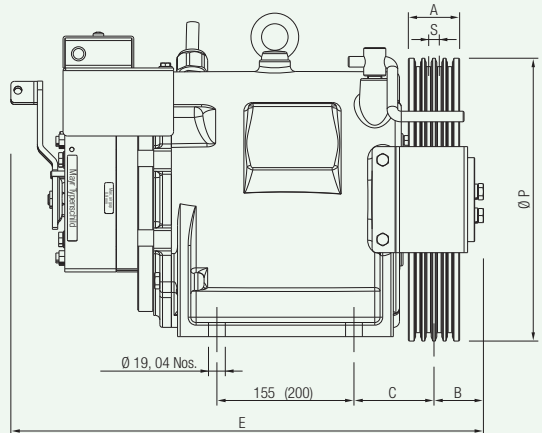
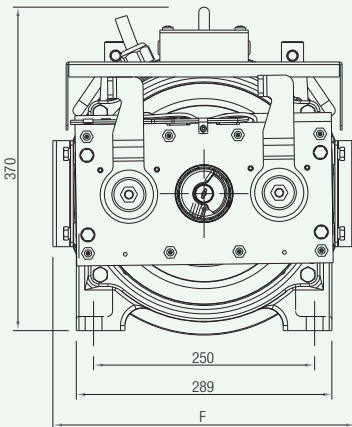

Weight of Machine (kg) : 162*

* Weight of machine is varies according to selection of sheave, motor & brake.

Subject to change without any prior notice !
All dimension are in mm.

SEG-20S

For Sharp Brake

Technical Drawing

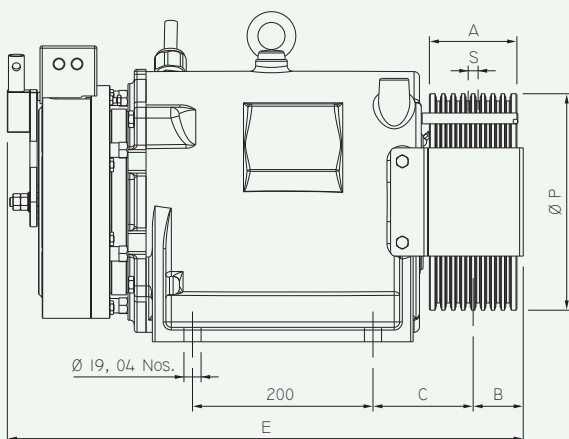
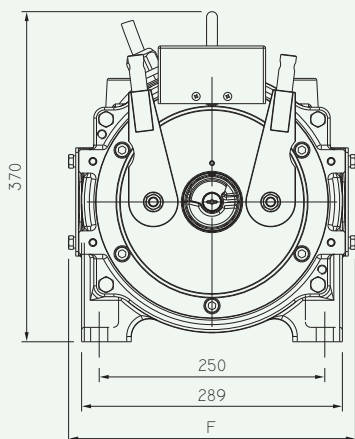

Weight of Machine (kg) : 162*

For Mayr Brake

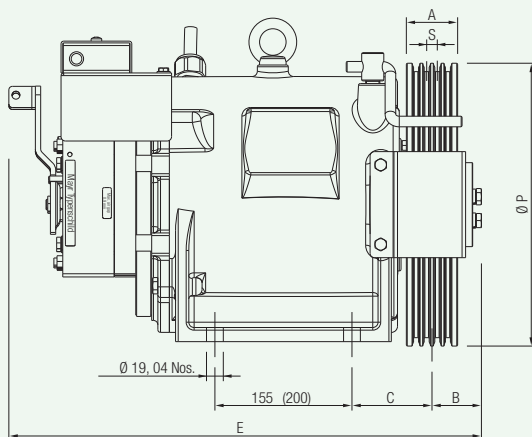
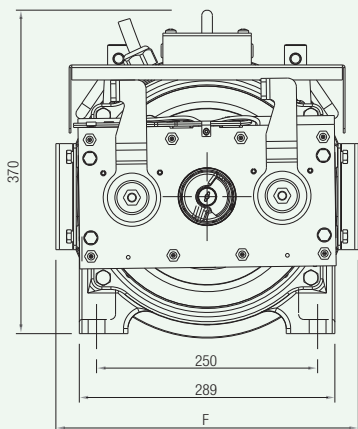

Weight of Machine (kg) : 162*

* Wight of machine is varies according to selection of sheave, motor & brake.

Subject to change without any prior notice !
All dimension are in mm.

SEG-30S

For Sharp Brake

Technical Drawing

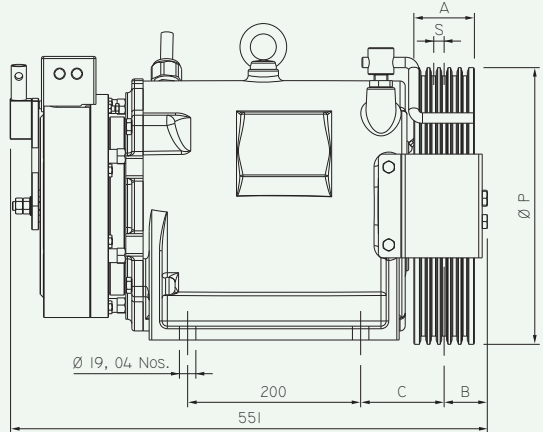
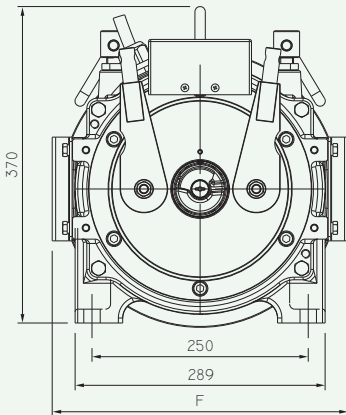

Weight of Machine (kg) : 167*

For Mayr Brake

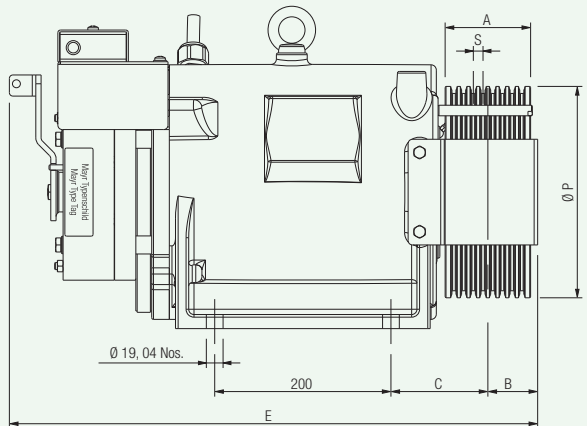
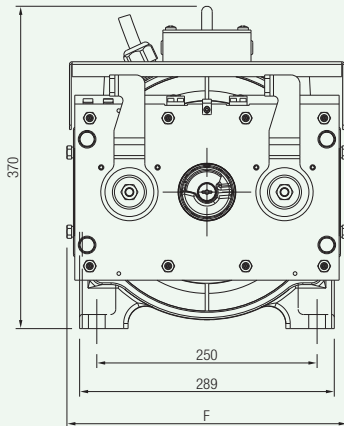

Weight of Machine (kg) : 176*

* Wight of machine is varies according to selection of sheave, motor & brake.

Subject to change without any prior notice !
All dimension are in mm.

SEG-35S

For Sharp Brake

Technical Drawing

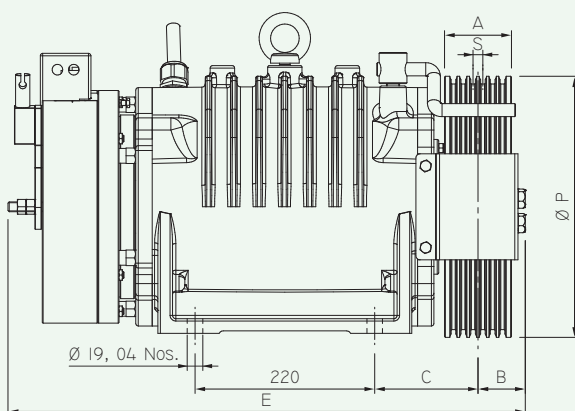
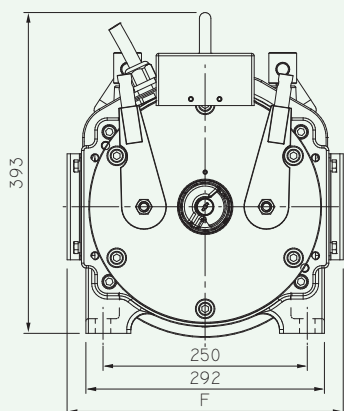

Weight of Machine (kg) : 220*

For Mayr Brake

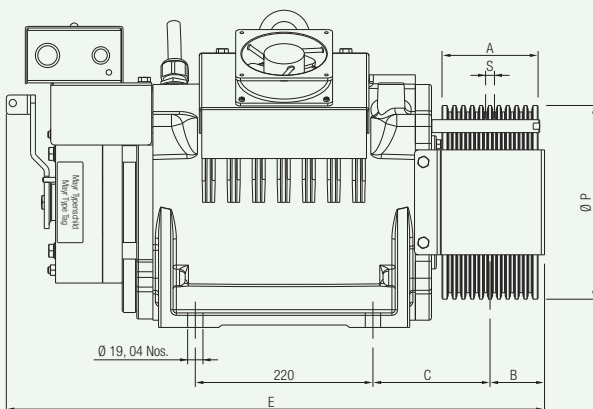
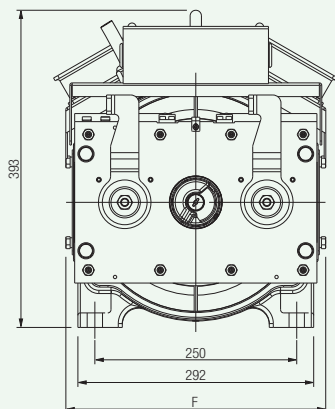

Weight of Machine (kg) : 220*

* Wight of machine is varies according to selection of sheave, motor & brake.

Subject to change without any prior notice !
All dimension are in mm.

SEG-40S

For Sharp Brake

Technical Drawing

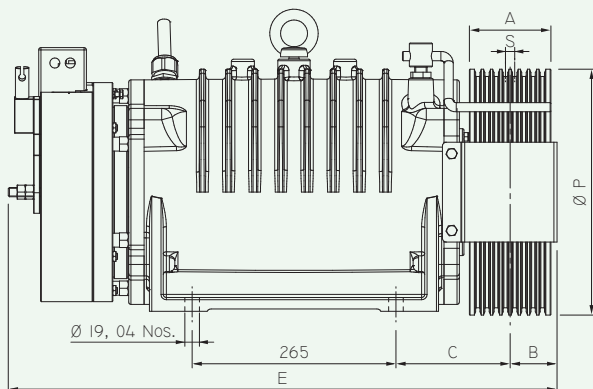
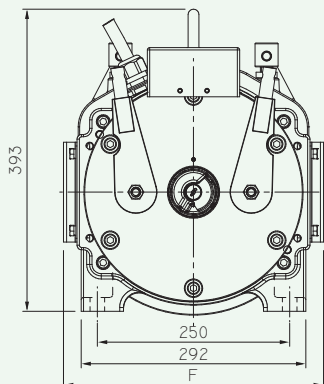

Weight of Machine (kg) : 245*

For Mayr Brake

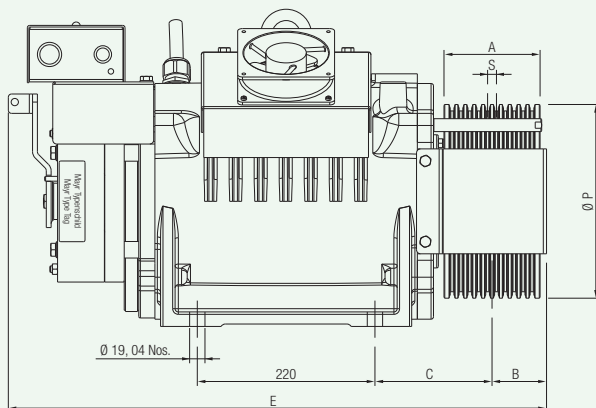
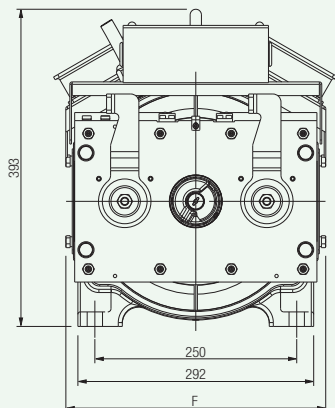

Weight of Machine (kg) : 265*

* Weight of machine is varies according to selection of sheave, motor & brake.

Subject to change without any prior notice !
All dimension are in mm.

SEG-45S

For Sharp Brake

Technical Drawing

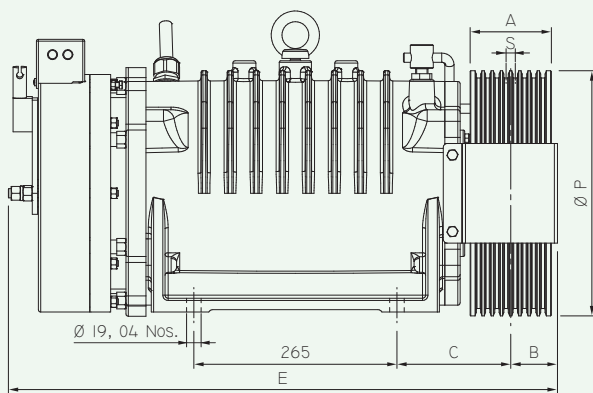
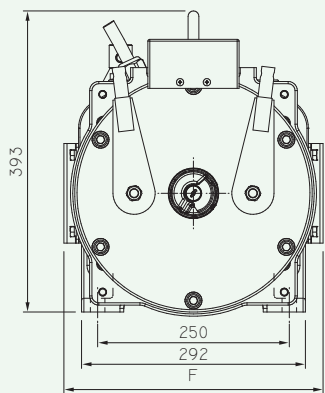

Weight of Machine (kg) : 265*

For Mayr Brake

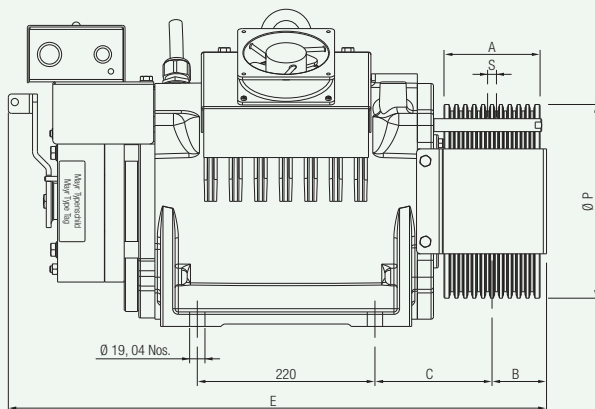
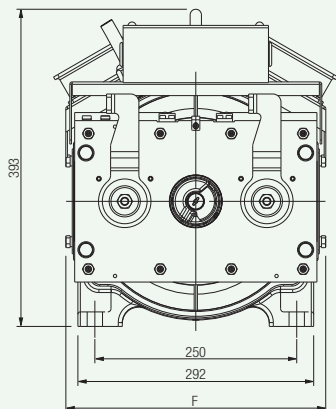

Weight of Machine (kg) : 265*

* Wight of machine is varies according to selection of sheave, motor & brake.

Subject to change without any prior notice !
All dimension are in mm.

SEG-50S

For Sharp Brake

Technical Drawing

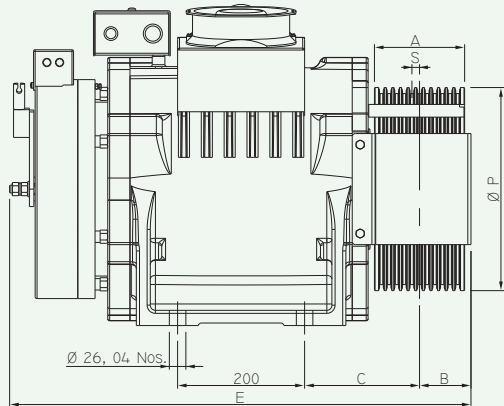
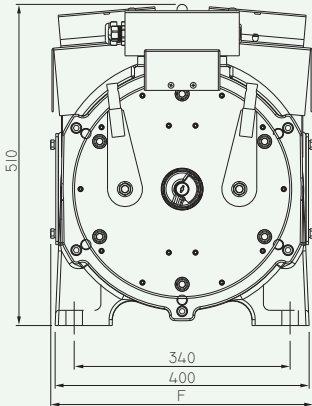

Weight of Machine (Kg) : 450*

For Mayr Brake

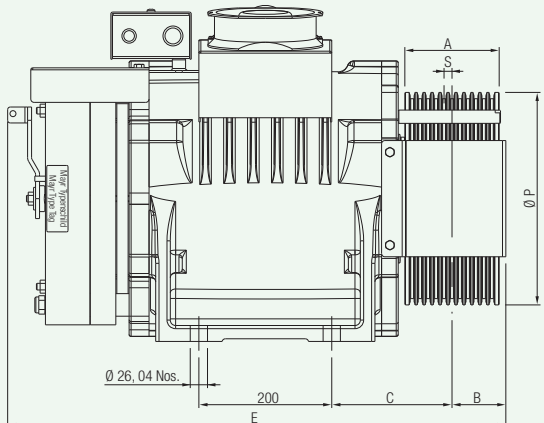
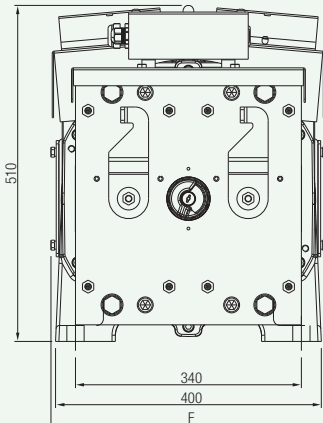

Weight of Machine (Kg) : 508*

* Wight of machine is varies according to selection of sheave, motor & brake.

Subject to change without any prior notice !
All dimension are in mm.

SEG-60S

For Sharp Brake

Technical Drawing

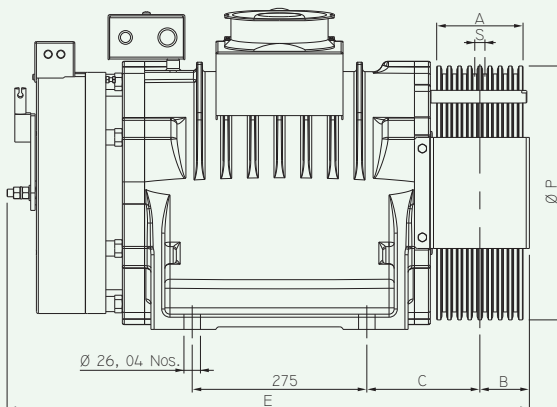
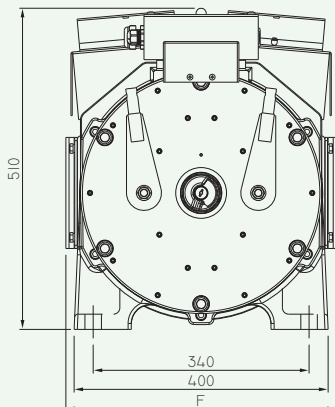

Weight of Machine (Kg) : 507*

For Mayr Brake

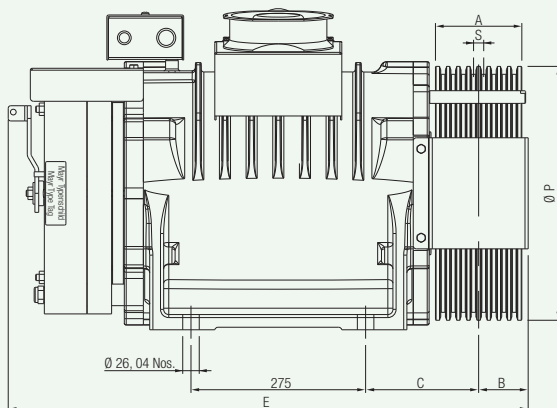
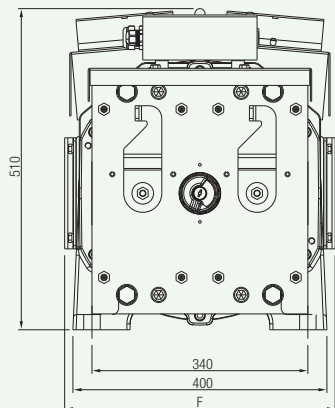

Weight of Machine (Kg) : 545*

* Wight of machine is varies according to selection of sheave, motor & brake.

Subject to change without any prior notice !
All dimension are in mm.

(SEG-70)

For Sharp Brake

Technical Drawing

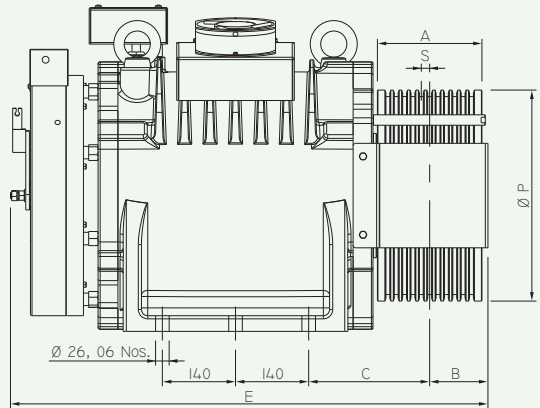
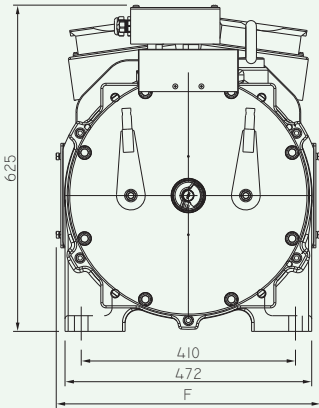

Weight of Machine (Kg) : 875*

For Mayr Brake

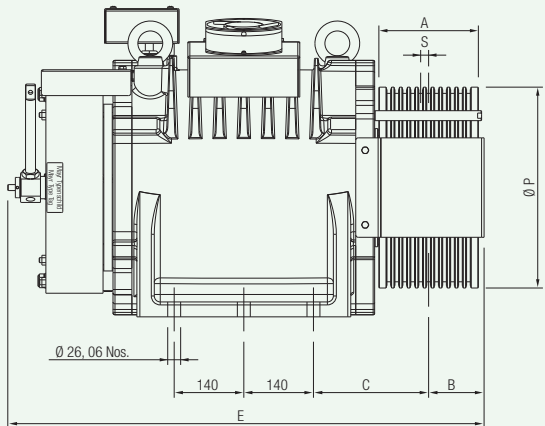
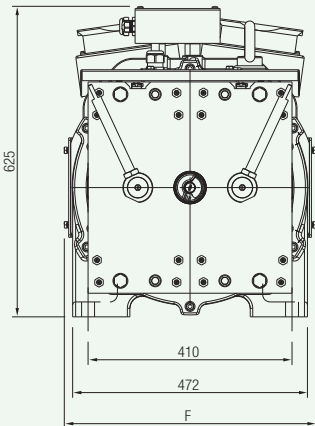

Weight of Machine (Kg) : 875*

* Wight of machine is varies according to selection of sheave, motor & brake.

Subject to change without any prior notice !
All dimension are in mm.

SEW-10

Technical Drawing

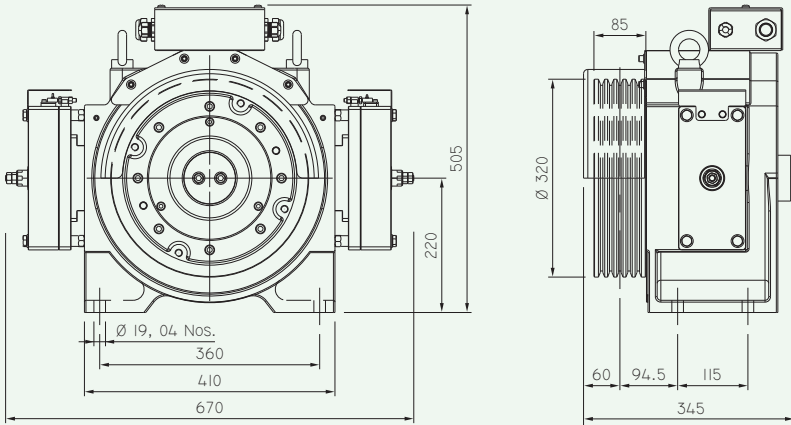

Weight of Machine (Kg) : 250*

SEW-20

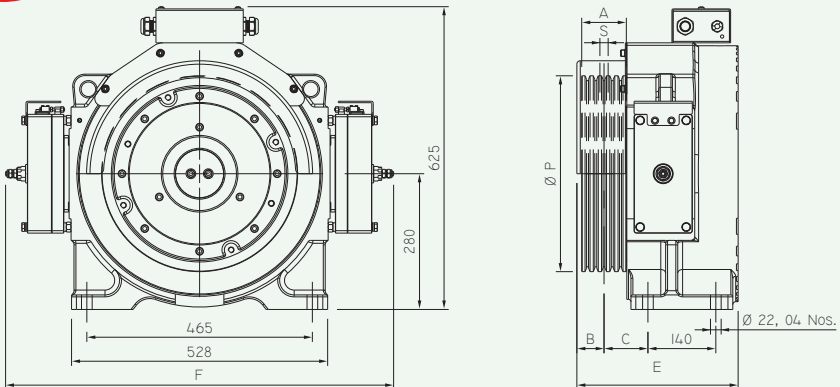

Weight of Machine (Kg) : 410*

Subject to change without any prior notice !
All dimension are in mm.

SEG β 1
Belt Drive

Technical Drawing

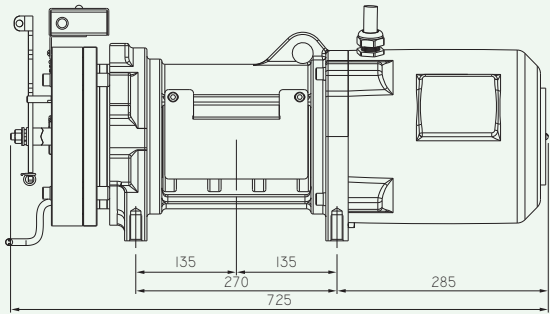
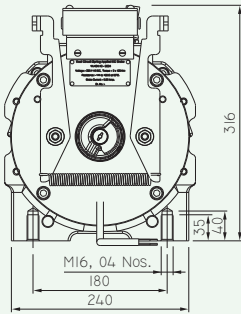



Weight of Machine : 125 Kg

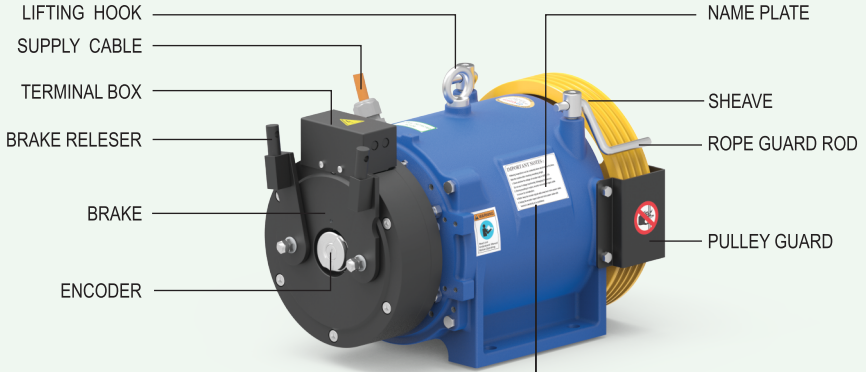

Subject to change without any prior notice !
All dimension are in mm.

* Kindly contact sales team for G.A. drawing of SEG-B2 & SEG-B3

03 - MACHINE IDENTIFICATION



		SEG-10S			
STATIC LOAD = 1700kg		DUTY LOAD = 408kg		ISO 9001:2015	
SHEAVE DETAIL = 320mm x 8mm x 4Grv					
SYNCHRONOUS MOTOR FOR DRIVING LIFT					
POWER = 3.0 Kw	VOLTAGE = 380 V, 3Ø	CURRENT (A) = 7.5			
FREQUENCY (Hz) = 19.9	POLE = 20	TORQUE (T) = 230Nm			
RPM = 119	SPEED (m/s) = 1.0	PROTECTION = IP 40			
RATING = S5 (40%)	ST/H = 180	IP = 40	INSUL. CLASS = F		
BRAKE VOLTAGE = 110 VDC		BREAKING TORQUE = 2 x 300 Nm			
SR. NO. :-		MONTH & YEAR :-			
SHARP ENGINEERS - GUJARAT (INDIA)					
www.sharpeengineers.com					

		SEG-20S			
STATIC LOAD = 1700kg		DUTY LOAD = 544kg		ISO 9001:2015	
SHEAVE DETAIL = 320 mm x 8 mm x 4 Grv					
SYNCHRONOUS MOTOR FOR DRIVING LIFT					
POWER (Kw) = 3.8	VOLTAGE = 380 V, 3Ø	CURRENT (A) = 11.2			
FREQUENCY (Hz) = 19.9	POLE = 20	TORQUE (T) = 305 Nm			
RPM = 119	SPEED (m/s) = 1.0	PROTECTION = IP 40			
RATING = S5 (40%)	ST/H = 180	IP = 40	INSUL. CLASS = F		
BRAKE VOLTAGE = 110 VDC		BREAKING TORQUE = 2 x 300 Nm			
SR. NO. :-		MONTH & YEAR :-			
SHARP ENGINEERS - GUJARAT (INDIA)					
www.sharpeengineers.com					

04 - SAFETY PRECAUTIONS

WARNING

The gearless lift machine should be installed in an area that is strictly kept under lock and key surveillance. Access to this area must be exclusively limited to a qualified installation & maintenance person who has been authorized by the user. At least the following notice must be affixed to the door that provides access to this area.

DANGER

USED BY AUTHORIZED PERSONNEL ONLY.

Before the lift machine is installed, the user must make sure that the support systems for moving loads and for the machine itself offer the required safety factors. The user **MUST ALSO** respect the distance from walls or other machines that is specified in the directives or standards which apply in the country where the machine is installed.

- Before performing any cleaning or maintenance operations. The maintenance worker must remove the lift machine from service by switching off the power supply and allow the hot motor and the machine itself to cool down to ambient temperature.
- Do not rest against or sit on the machine, whether it is in service or out-of-service.
- Do not approach or lean against rotating parts (traction-sheave yellow painted).
- Do not rest objects, containers of liquids, etc. on the machine on its electrical components.
- Never tamper with or deactivate the safety systems. Also, never bypass these systems or use them for purposes other than those for which they are intended.
- Do not tamper, degrade or remove the identification plates. If a plate should deteriorate and become illegible, contact SHARP ENGINEERS immediately for a replacement.
- When working around the machine the installation and maintenance person **MUST NEVER WEAR FLUTTERING AND/OR TORN CLOTHING** (i.e., scarves, ties, hats, necklaces, straps, watches, bracelets around the wrists, rings on the fingers, etc.) Warning refers to a hazard or unsafe method or practice which **CAN** result in service personal injury or possible death.
- Depending on the working conditions the surface temperature can be very high.

DANGER

- Do not lift higher loads with these eyelets for example a socket, ropes, etc.
Danger of life!
- Safety components, e.g. the brake release monitoring, may neither be disassembled nor by-passed or disabled.

05 - TRANSPORT & STORAGE



- Transport the Gearless Lift Machine either with the original packing or at the coasted eyelets using adequate hoists.
- Avoid impacts and shocks.
- Check packing and motor for possible damage and report the forwarding agency about any damages caused by transport. Shipping damages are not covered by our guarantee.
- Store the motor in a dry, weatherproof place in its original packing or protect it from dirt and climatic influences until the final installation.
- Avoid extreme heat or cold (storage temperature – 20 °C until + 60 °C)
- Avoid excessive storage times (we recommend max one year) and check motor bearing for correct function before installing the motor.

a) Packing & Lifting :-



Packing Stage -01



Packing Stage – 02



Final Packing

b) Removal from packing & Handling the machine :-

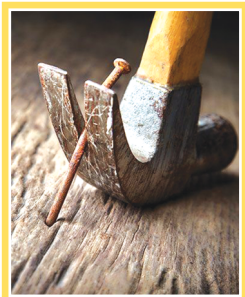

Removing Nail



Remove Wooden Box



Lifting Machine

06 - COMMISSIONING :-

The following points should be checked or completed before functioning Gearless Machine :

- Remove all securing, auxiliary and installation tools from the danger area.
- Check that the lift machine is used for its intended purpose and that the permissible ambient conditions are met.
- Check that the lift machine is properly fastened.
- Are all bolts tightened with the specified torque and secured?
- Check the motor connection and Earthing, see Motor Connection detail in manual and follow process.
- Check the brake Connection, See Brake Connection detail in manual and ensure proper functioning of brake.
- Check the Encoder cable connection, See Encoder Connection detail in manual and ensure proper connection of encoder cable before functioning.
- Check that the offset value indicated on the measuring system (Encoder) agrees with the value set on the Drive system.
- Check the proper functioning of the brake;
- Is the rope guard properly tightened and adjusted?
- An initial function test of the motor and the brake, together with the drive, should be performed before the ropes are put in place ,
- Applied half of full load on inspection mode for testing the machines, Do not apply full load immediately , Test must be carried out 30 minutes for observing performance of machine.
- Now increase the load upto 100 % load and observe the output reading in control system.

07 - ELECTRIC CONNECTION

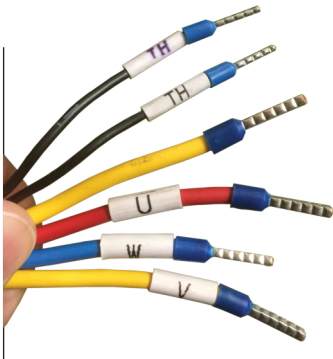

7.1 - MOTOR CONNECTION

We are providing main Supply cable 4 core wire with 7* meter length, We mark U, V, W identification on wire for three phase power supply and TH for thermistor wire & remaining wire for Earthing,

* 7 meter supply cable providing for machine
SEG - 05, SEG - 10, SEG - 20, SEG - 30,
SEG - 40, SEG -/31.

7.2 - BRAKE CONNECTION CAUTION

CONNECTION DIAGRAM FOR SEG - 05, SEG - 10, SEG - 20, SEG - 30 & SEG - β1.

SHARP BRAKE 110 VDC

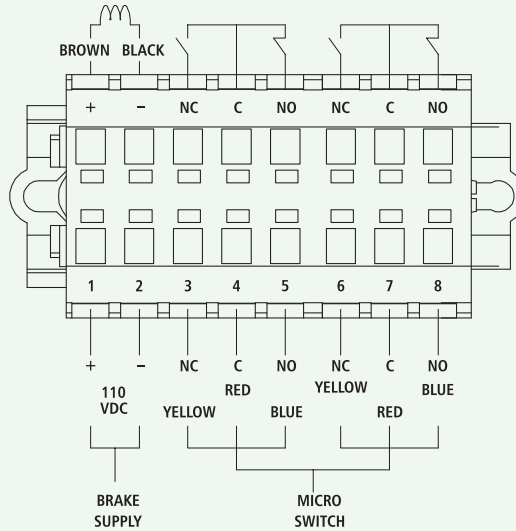

MAYR BRAKE 104 VDC

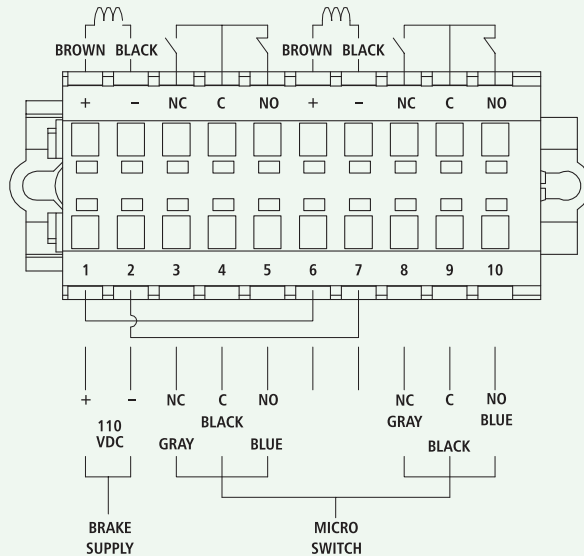

CONNECTION DIAGRAM FOR SEG - 40

SHARP BRAKE 110 VDC

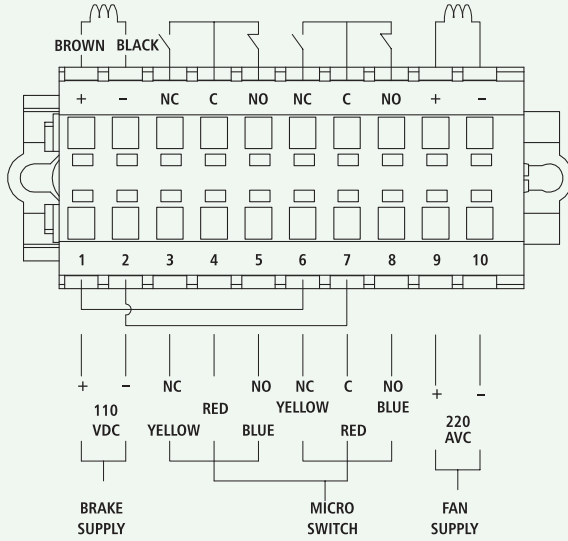

MAYR BRAKE 104 VDC

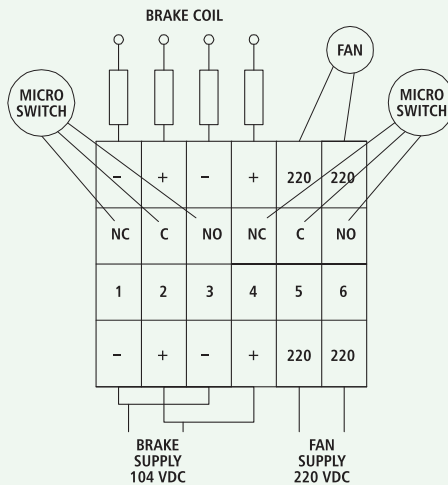

CONNECTION DIAGRAM FOR SEG - 50, SEG - 60 & SEG - 70.

SHARP BRAKE 110 VDC

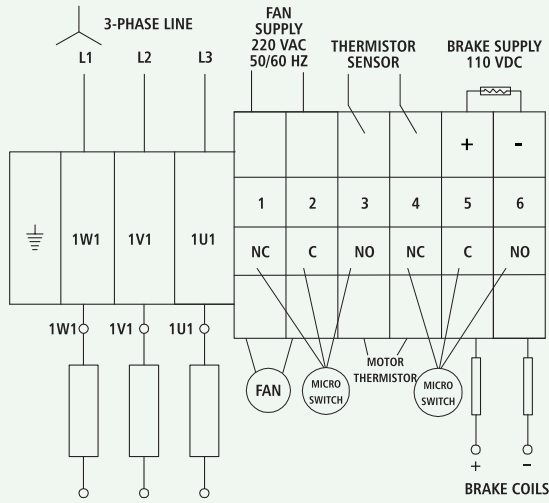

MAYR BRAKE 104 VDC

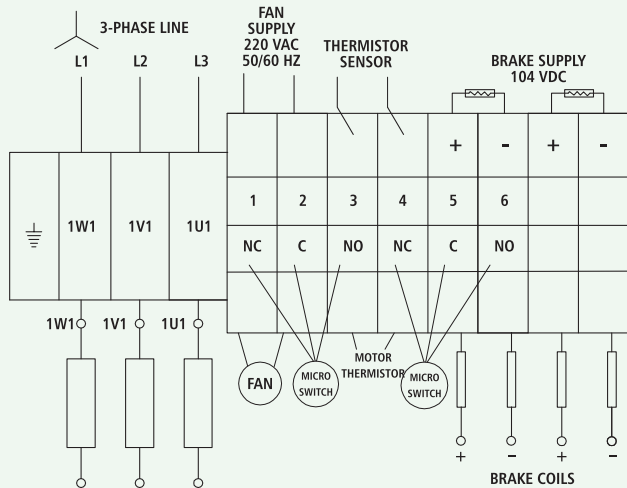

CONNECTION DIAGRAM FOR SEW - 10 & SEW - 20.

CONNECTION DIAGRAM

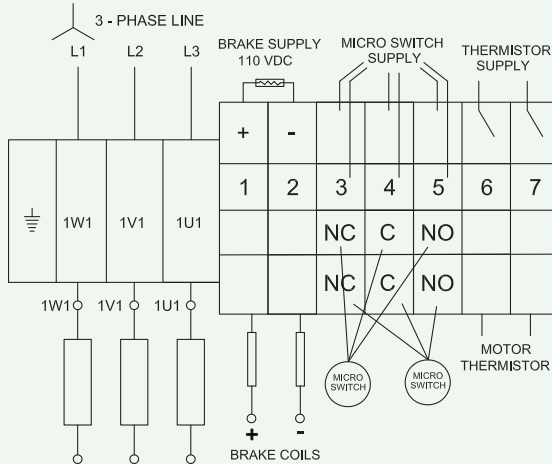

7.3 - BRAKE MICRO SWITCH :-

Function :

- There are two Micro switches for brake operation monitoring to protect the motor.
- When brake is properly open at that time micro switch is in function (Normally Close) and give single to drive to run motor,
- In case of brake is not properly open at that time micro switch is not in function (Normally Open) and do not give signal to drive to run motor.
- For Micro Switch connection refer above diagram.

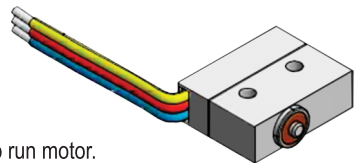

08 - THERMAL PROTECTION OF MOTOR :-

FUNCTIONAL DESCRIPTION

- The PTC Sensors are normally embedded in the motor windings. Normally 1 set of Sensors consists of 3 connected in series (1 thermistor per phase). These thermistors are to be connected to the respective terminal on the thermistor Protection Relay.
- Under normal temperature conditions, the Relay permits supply to the starter coil of motor whenever the tripping temperature is attained it cuts of the supply to the starter coil & trips the motor. When the winding temperature reduces below a safe level, the Relay resets and restores the supply to starter coil. Thus the winding of motor is protected from overheating and burning.

REQUIRE RELAY FOR PTC SENSOR.

Technical Data

Supply Voltage	110 / 230 / 380 / 415 VAC \pm 10 % 50 Hz 24 VDC \pm 10 %
Output Contacts	2 Changeover (2 No + 2NC) Potential Free
Input	Max. 6 numbers RTC Thermistors
Rated at	4 Amps 230 Volts.
Ambient Temp	-5°C to + 55 °C
Operational Lift	1 million on / off Operations

09 - OVER EXCITATION SWITCH (RECTIFIER SWITCH) CONNECTION:

Function :

- Rectifier is a fast acting Over excitation switch which initially gives higher DC Voltage for a few milliseconds.
- The rectifier units are used for operation at an input voltage of 230 VAC,
- They can switch internally from bridge rectification and output voltage is 220 VDC for 0.05 to 2.0 seconds and than switch over to 110 VDC,

Specification :

Input Voltage	230 VAC
Output Voltage	103 VDC
Current	2.0 Amp. DC

Connection Diagram :

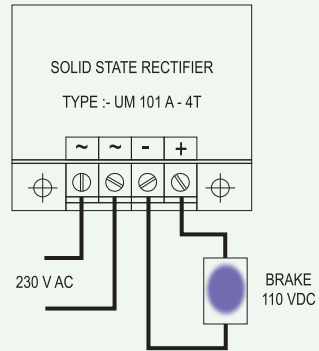

10 - ENCODER CONNECTION (Encoder ERN - 1387):

- We are providing Encoder cable with 7 meter length with all gearless machines.
- Encoder cable is kept in bag separately in Machine Box, So first collect Encoder cable from box.
- Encoder cable have 14 wire with one side pin which is going to connect in Encoder socket and on other end of encoder cable there are 14 wire with ferrul mark to connect with Drive PG Card, In case of loss ferrul mark on wire follow below pin layout connection ,

PIN LAYOUT FOR CONNECTION ERN-1387 :-

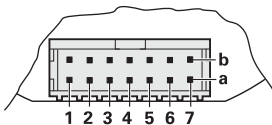

Cable shield connected to housing (see 6.)

1b	7a	5b	3a	6b	2a	3b	5a	4b	4a	7b	1a	2b	6a
Up	Sensor Up	0V	Sensor 0V	A+	A-	B+	B-	R+	R-	C+	C-	D+	D-

The sensor line is connected inside the encoder to the supply line.



WARNING

The electrical connection may only be made by a qualified electrician.

Power supply

Up = 5V ± 5%
 Imax. 130 mA
 (ohne Last, Without load, sans charge,
 EN 50 178
 PELV ± EN 60204-1

11 - MAINTENANCE :-

General :-

- The regulations concerning operation, maintenance and inspection pursuant to the applicable safety regulations for lift construction such as DINEN81 "Safety rules for the construction and installation of lifts", Part 1 "Electric lifts", and other relevant regulations are to be strictly observed.
- The operator is responsible for ensuring that the motor is installed properly and in accordance with the safety requirements, as well as for its inspection and maintenance as specified in the applicable regulations.
- The proper maintenance of gearless lift machines requires adequately trained specialist personnel and special devices and tools.
- Repairs other than those described in these operating instructions are not to be carried out by the lift fitter/maintenance technician for liability reasons.

Maintenance Intervals :-

Point To Be Consider	At Initial Operation Resp. After 3 Months	After 6 Month	Every Year
Cleaning	✓	✓	✓
Brake Air Gap		✓	✓
Bearing		✓	✓
Electrical Cables		✓	✓
Visual Check of the Bolts and Screw	✓	✓	✓
Check Traction Sheave for wear out			✓

12 - HOW TO REPLACE SHEAVE :-

- First of all Remove allen bolt (1) with the help of the spanner.
- Now remove Pulley washer (2) than after put nut between pulley washer and shaft face, Now match pulley's thread with pulley washer's outer hole and tight slowly all three allen bolt equally to remove the pulley.
- Now follow reverse process for reassemble the pulley.

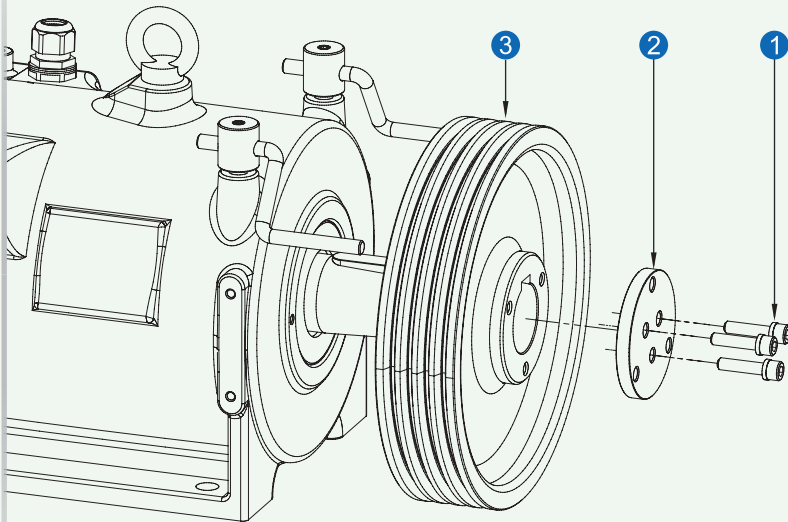

13 - HOW TO DISASSEMBLE AND ASSEMBLE ENCODER:

DISASSEMBLY STEP FOR ENCODER:-

- Disassembly in reverse order.
- Tow ways of pressing the encoder out during dismantling.

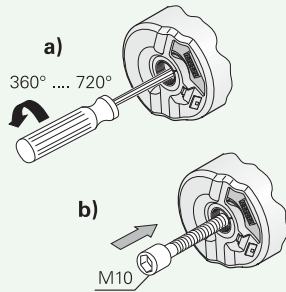
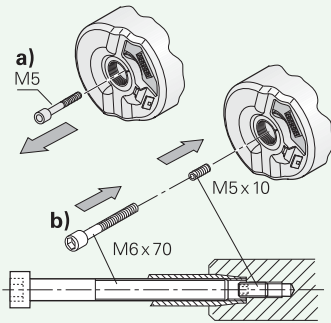

ASSEMBLE STEPS FOR ENCODER

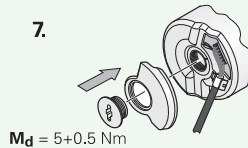
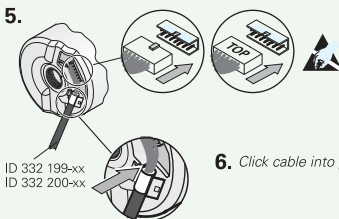
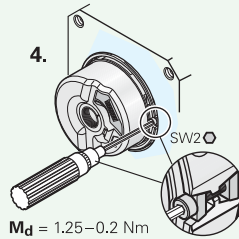
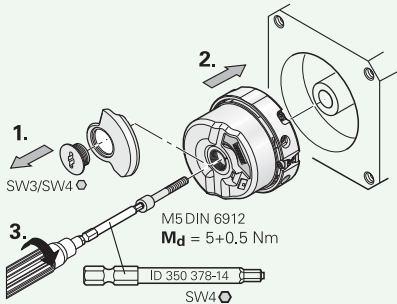

6. Click cable into place, and push it in as far as possible

14 - MANUAL BRAKE OPERATING ATTACHMENT :

14.1 - MANUAL OPERATION IN CASE OF EMERGENCY :- FOR SEG SERIES

1. Switch off the main switch in machine room.
2. Operate manual operating devices as shown in by rotating handle for release the brake and lift move In high load side.



14.2 - MANUAL OPERATION IN CASE OF EMERGENCY :- FOR SEW SERIES

1. Switch off the main switch in machine room.
2. Operated manual operating Lever as shown in by rotating Lever by hand for release the brake and lift move in high load side.

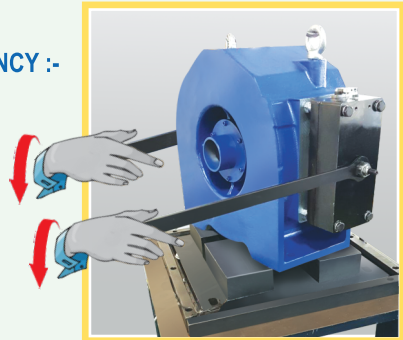

15 - OPTIONAL EMERGENCY RESCUE DEVICE :

- We are providing Optional Emergency Mechanical Rescue Device,
- For operating Emergency Rescue Device, First open Brake by means of Manual Brake Operating attachment,
- Now Connect Hand releaser to Sheave Gear and match proper gear and rotate hand releaser by hand in appropriate direction to reach nearest floor,

For SEG SERIES

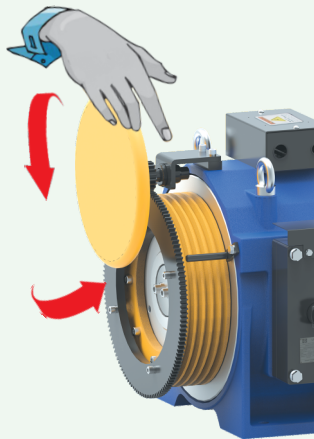
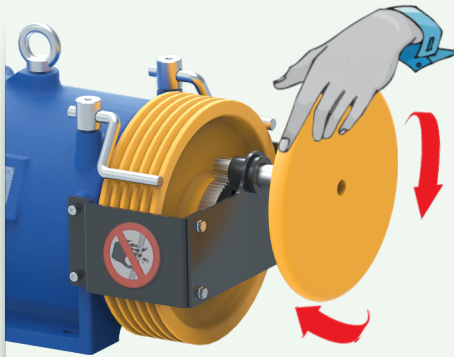

For SEW SERIES

16 - TROUBLE SHOOTING : 

Fault	Cause	Root Cause
Running Noise	Bearing Noise Motor Noise Brake Noise	Contact Customer Service Check Motor parameter Check Brake Function
Motor will not start	Motor Phase Connect incorrect Encoder Tuning with drive Brake dose not release	Check motor Connection Check encoder tuning with drive Check Brake Connection
Brake dose not release	Power supply to low Brake control wrong / defective Brake defective	Check power supply Check brake control Change brake

SPARE PARTS  **WARNING**

Spare parts and accessories not supplied by **SHARP ENGINEERS** have not been tested or approved by us. These parts may be lower in function or quality and therefore can reduce functionality or safety of the installation. **SHARP ENGINEERS** will assume no liability or guarantee for damages caused by spare parts that are not approved.

Customer Service Address

SHARP ENGINEERS

Plot No : - 552, Road - A Cross Road - 12, G.I.D.C. Kathwada, Ahmedabad - 382430

Contact No :- 097129 42141 E-mail :- service@sharpengineers.com

17 - WARRANTY :

1. Unless otherwise agreed upon in the sales contract, this warranty is governed by the following clauses:
 - The warranty on SHARP ENGINEERS products is valid for a period of One year from the date shown on the shipping papers. During the warranty period, SHARP ENGINEERS will replace without charge an component that has been recognized as defective.
 - A component can be declared defective only if the relative defect has been recognized by SHARP ENGINEERS.
 - Components that are to be required or replace under warranty must be sent to SHARP ENGINEERS with all shipping and duty fees prepaid.
 - Request to SHARP ENGINEERS for service calls must be made by the customer in writing.
 - Labor, room and board, and travel costs must be paid for by the customer.
2. This warranty will automatically become null and void if any of the following circumstance occur:
 - The component for which warranty service has been requested has tampered with.
 - The machine has been used in any application which was not previously authorized by or agreed upon with SHARP ENGINEERS in writing.
 - The machine has been used in a way that does not conform to the specification for which it has been built, as indicated in the technical manual and in this Operation and Maintenance Manual.
 - The identification plates are missing, or it is impossible to identify the machine.
3. The following components, which are subjected to normal wear, are not included in this warranty brake linings, roll bearings, electrical windings.
4. This warranty does not include compensation for shipping fees or down time.

5. All warranty claims must be communicated to SHARP ENGINEERS by mail (or by fax) within 8 days from the day that the relative problem occurs.
- SHARP ENGINEERS will conform by mail (or by fax) the eventual acceptance of proposed repairs to be executed by the customer will send its own technical personnel.
 - Any defective material replaced by the customer must remain at SHARP ENGINEERS disposition for 30 days so that the necessary verification can be performed; or, the material must be shipped to SHARP ENGINEERS when the company so requests in writing.
 - Absolutely no claims will be accepted for warranty repairs that were not previously authorized in writing by SHARP ENGINEERS.
 - In any case, a complete photographic study of the executed repairs operation must be supplied to SHARP ENGINEERS to correct the problem and improve the quality and reliability of its machines.
 - SHARP ENGINEERS reserves the right to ask back defective materials in order to check the cause of the problem. If defective materials don't reach SHARP ENGINEERS by 30 days from SHARP ENGINEERS request, the new part will be invoiced to the customer.

Disposal Method of Machine after coddle life :

All the parts in Machine are used as per latest environmental protection law, after the coddle life of this machine can be disposed off as follow.

The Parts of Cast Iron, Steel, M.S, Magnet material and copper can be reclaimed as a scrape, the insulated wire, plastic, Electronic printed circuit board, corrugated paper wooden box etc may be disposed off as per National and local law of environment protection.

Global
Presence



SHARP ENGINEERS

552, 'A' Road, Cross Road No - 12,
G.I.D.C., Kathwada, Ahmedabad - 382430,
Gujarat, INDIA.

Tele : + 91 79 2290 1711, 12, 14, 15.

E-mail : info@sharpengineers.com

sales@sharpengineers.com

Website : www.sharpengineers.com