

SEG SERIES

Gearless Traction Machine

SEG-40S

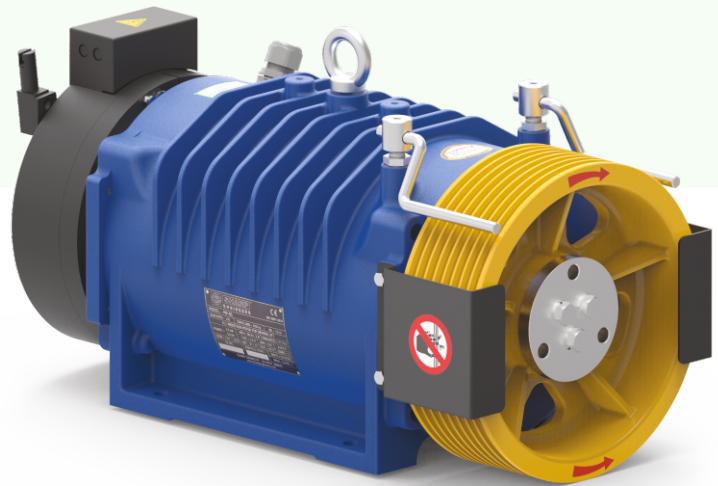

Voltage
400 V



Suspension
2:1



Brake
110 VDC



Max. Static Load
4800 Kg



Weight of Machine (kg)
245*

* Weight of machine is varies according to selection of sheave, Motor & Drive system.

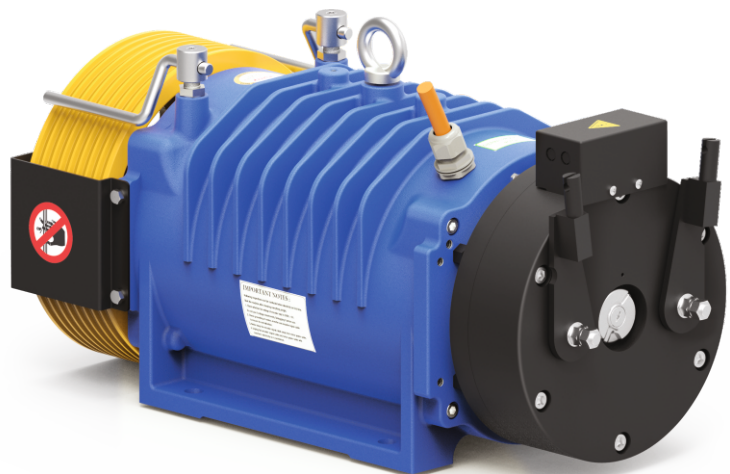

Gearless Traction Machine

SEG-40S

Specification	Load (kg)	Lift Speed (m/s)	Height (m)	Sheave Dia (mm)	No. of Groove X Rope Dia	Current (A)	Toque (Nm)	Rated Speed (rpm)	Frequency (Hz)	Power (kW)	Pole	Rating	INS Class.	IP Code
S40S-20P1A0	1360	1.00	≤ 80	Ø240	10 X Ø 6.5	21.0	550	159	26.5	9.1	20	S5 (40%)	F Class	IP-40
S40S-20P1A5		1.50			10 X Ø 6.5	28.0	550	239	39.8	13.7				
S40S-20P1A75		1.75			10 X Ø 6.5	33.0	550	279	46.4	16.0				
S40S-16P1B0	1088	1.00	≤ 80	Ø320	7 X Ø 8.0	19.0	590	119	19.9	7.4	20	S5 (40%)	F Class	IP-40
S40S-16P1B5		1.50			7 X Ø 8.0	24.0	590	179	29.8	11.0				
S40S-16P1B75		1.75			8 X Ø 8.0	27.5	590	209	34.8	12.9				
S40S-16P2B0		2.00			8 X Ø 8.0	30.5	590	239	39.8	14.7				

Kindly contact us for various speed and load combination

ØP	A	B	C	N X ØD	E	F	S
Ø240	119	67.5	155	10 X Ø 6.5	728	324	11

ØP	A	B	C	N X ØD	E	F	S
Ø320	106	61	148.5	8 X Ø 8	715	338	12

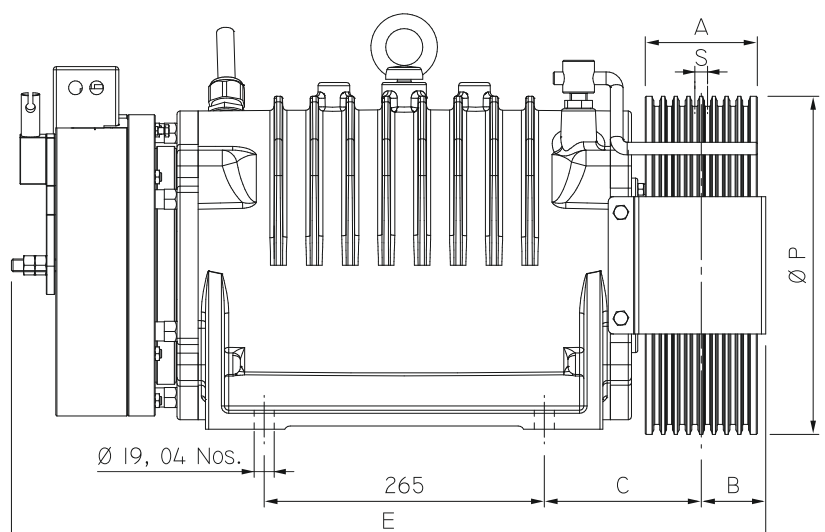
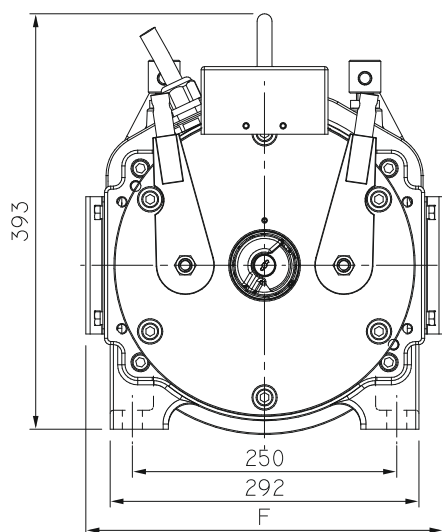

(All dimensions are in mm)