

# SEG SERIES

Gearless Traction Machine

(*SEG-70*)



Voltage  
400 V



Suspension  
2:1



Brake  
110 VDC



Max. Static Load  
10500 Kg



Weight of Machine (kg)  
875\*

\* Weight of machine is varies according to selection of sheave, Motor & Drive system.



# Gearless Traction Machine

## (SEG-70)

Specification	Load (kg)	Lift Speed (m/s)	Height (m)	Sheave Dia (mm)	No. of Groove X Rope Dia	Current (A)	Toque (Nm)	Rated Speed (rpm)	Frequency (Hz)	Power (kW)	Pole	Rating	INS Class.	IP Code
S70-2500P1B0	2500	1.00	≤ 80	Ø400	9 X Ø10.0	46.0	1690	96	19.1	16.9	24	S5 (40%)	F-Class	IP-40
S70-2500P1B5		1.50			9 X Ø10.0	64.0	1690	143	28.6	25.3				
S70-2500P2B0		2.00			9 X Ø10.0	72.0	1690	191	38.2	33.8				
S70-3000P1B0	3000	1.00	≤ 80	Ø400	11 X Ø10.0	60.0	2020	96	19.1	20.1	24	S5 (40%)	F-Class	IP-40
S70-3000P1B5		1.50			11 X Ø10.0	78.0	2020	143	28.6	30.2				
S70-3000P2B0		2.00			11 X Ø10.0	86.0	2020	191	38.2	40.3				
S70-3000P1C0	3000	1.00	≤ 80	Ø450	10 X Ø11.0	61.0	2250	85	17.0	20.1	24	S5 (40%)	F-Class	IP-40
S70-3000P1C5		1.50			10 X Ø11.0	76.0	2250	127	25.5	30.2				
S70-3000P2C0		2.00			10 X Ø11.0	91.0	2250	170	34.0	40.3				
S70-3000P2C5		2.50			10 X Ø11.0	96.0	2250	191	38.2	45.0				

Kindly contact us for various speed and load combination

ØP	A	B	C	N X ØD	E	F	S
Ø400	200	112	232	9 X Ø10	915	510	16
				11 X Ø10			

ØP	A	B	C	N X ØD	E	F	S
Ø450	185	105.5	224.5	10 X Ø11	900	510	16

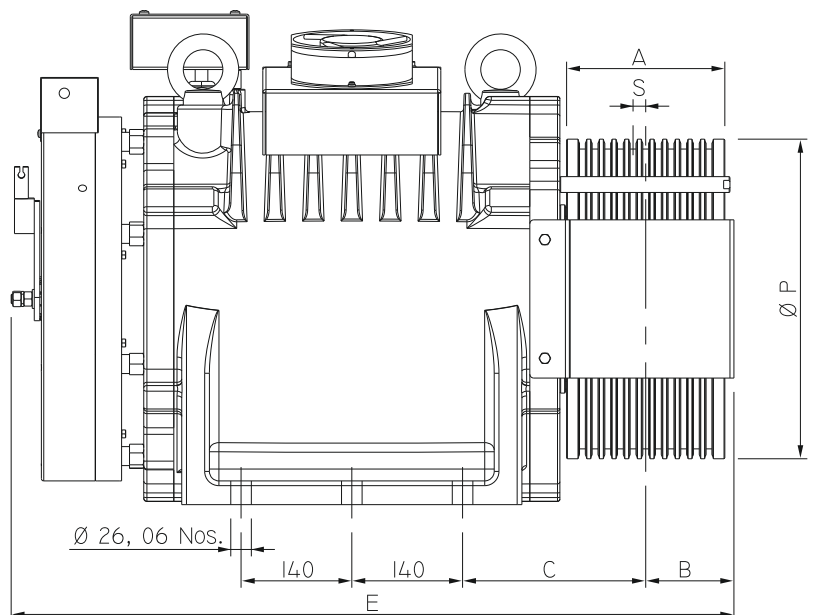
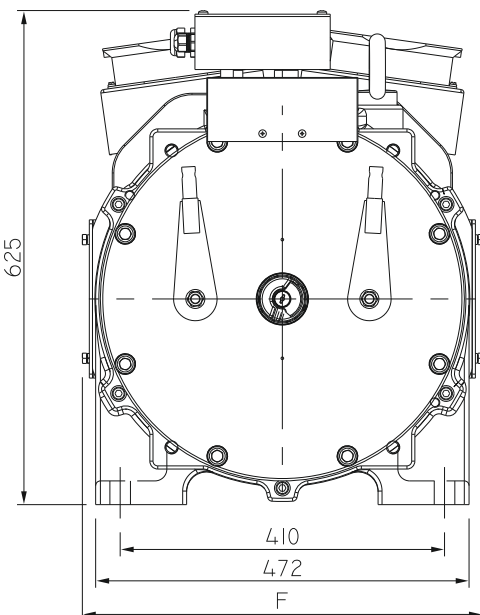

(All dimensions are in mm)