

### SPECIFICATION

Roping		1:1
Max. Sheave shaft Load	lbs (Kg)	26700 ( 12110)
Max. Elevator Capacity 100%	lbs (Kg)	3500 (1588)
Max. Elevator Speed	fpm (m/sec)	500 (2.54)
Sheave Diameter / Rope Size / No. of Ropes	Inch	Ø25" X 5/8" X 6 Ropes
Max. Rated Power	Kw (HP)	26.7 (35.8)
Max. Rated Torque	ft-lbs (Nm)	2463 ( 3339)
Max. Rated Torque (125%)	ft-lbs (Nm)	3079 ( 4174)
Rated Voltage	V	380
Brake Torque at Sheave (125%)	ft-lbs (Nm)	3128 ( 4241)
Emergency Brake Torque	ft-lbs (Nm)	3128 ( 4241)
Machine Weight	lbs (Kg)	4200 (1905)*

\* Weight of machine is varies according to selection of Sheave, Motor & Drive system.

- CSA B44.1/ASME A17.5 Certification

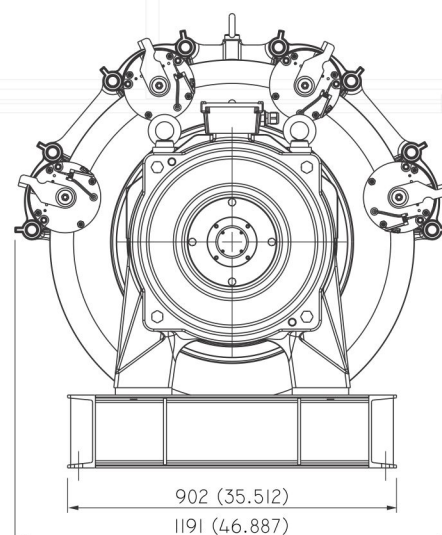
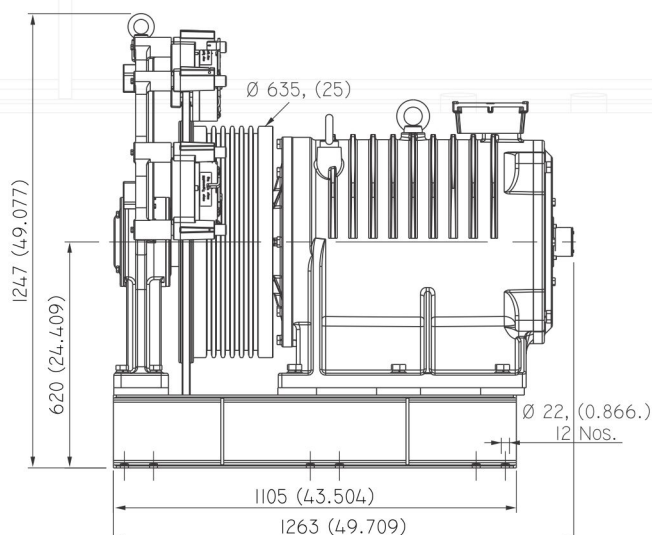

Subject to change without any prior notice!

All Dimension are in mm (inch).



**MACHINE DUTY TABLE :**

**ROPING : 1:1**

**BALANCING : 40%**

Description	Elevator Duty		Car Speed		Rated Power		Rated Speed	Rated Freq.	Rated Voltage	Rated Current	Rated Torque		Main Sheave
	(lbs)	(Kg)	(fpm)	(m/sec)	(HP)	(kW)	(RPM)	(Hz)		(A)	(Nm)	(ft/lbs)	
SEGX72515025	2500	1134	150	0.76	8.0	5.9	23	4.5	380	38.0	2479	1828	Ø25" x 5/8" x 6 Groove OR Ø25" x 1/2" x 7 Groove
SEGX72520025	2500	1134	200	1.02	10.7	8.0	31	6.1	380	38.0	2479	1828	
SEGX72525025	2500	1134	250	1.27	13.3	9.9	38	7.6	380	38.0	2479	1828	
SEGX72530025	2500	1134	300	1.52	15.9	11.9	46	9.0	380	38.0	2479	1828	
SEGX72535025	2500	1134	350	1.78	18.6	13.9	54	10.7	380	38.0	2479	1828	
SEGX72540025	2500	1134	400	2.03	21.2	15.8	61	12.2	380	51.0	2479	1828	
SEGX72545025	2500	1134	450	2.29	24.0	17.9	69	13.8	380	51.0	2479	1828	
SEGX72550025	2500	1134	500	2.54	26.6	19.8	76	15.3	380	51.0	2479	1828	
SEGX73515025	3500	1588	150	0.76	10.7	8.0	23	4.5	380	50.0	3339	2463	Ø25" x 5/8" x 6 Groove
SEGX73520025	3500	1588	200	1.02	14.5	10.8	31	6.1	380	50.0	3339	2463	
SEGX73525025	3500	1588	250	1.27	18.0	13.4	38	7.6	380	50.0	3339	2463	
SEGX73530025	3500	1588	300	1.52	21.5	16.0	46	9.0	380	50.0	3339	2463	
SEGX73535025	3500	1588	350	1.78	25.08	18.7	54	10.7	380	50.0	3339	2463	
SEGX73540025	3500	1588	400	2.03	28.6	21.3	61	12.2	380	64.0	3339	2463	
SEGX73545025	3500	1588	450	2.29	32.3	24.0	69	13.8	380	64.0	3339	2463	
SEGX73550025	3500	1588	500	2.54	35.8	26.7	76	15.3	380	64.0	3339	2463	