

ALL DIMENSION ARE IN MM UNLESS OTHERWISE SPECIFIED.

THE INFORMATION CONTAINED IN THIS DRAWING IS THE ONLY PROPERTY OF SHARP ENGINEERS ANY REPRODUCTION IN PART OR AS WHOLE WITHOUT THE WRITTEN PERMISSION OF SHARP ENGINEERS IS PROHIBITED.

|              |             |      |             |                         |            |       |  |
|--------------|-------------|------|-------------|-------------------------|------------|-------|--|
| REVISION No. | DESCRIPTION | DATE | APPROVED BY | DRWN BY<br>KM           | SIZE<br>A4 | SCALE | TITLE:-<br>SEG-30<br>G.A.DRAWING WITH MANUAL RELEASE |
|              |             |      |             | DRWN DATE<br>05-06-2020 |            |       |  |

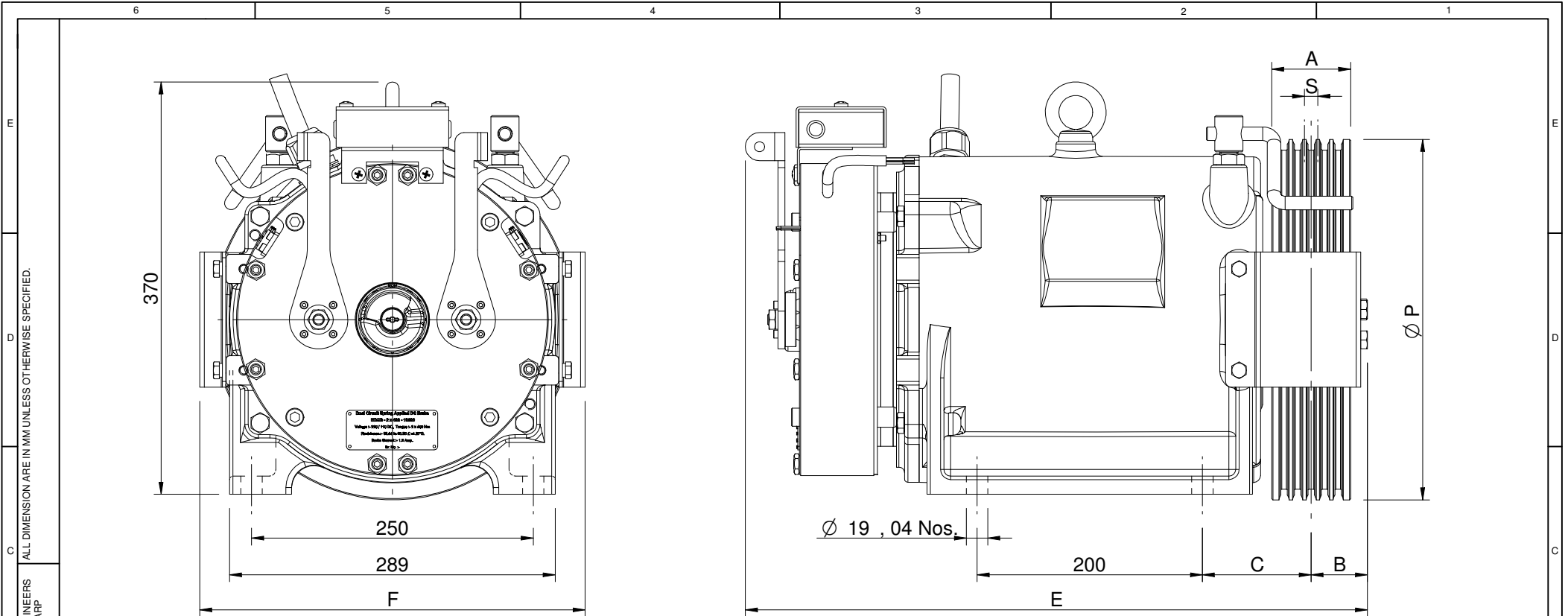



| ØP   | A  | B    | C   | N X ØD   | E   | F   | S  |
|------|----|------|-----|----------|-----|-----|----|
| Ø240 | 97 | 58.5 | 110 | 8 X Ø6.5 | 575 | 320 | 12 |

| ØP   | A  | B  | C     | N X ØD     | E   | F   | S  |
|------|----|----|-------|------------|-----|-----|----|
| Ø320 | 82 | 50 | 120.5 | 5/6 X Ø8.0 | 560 | 345 | 12 |

THE INFORMATION CONTAINED IN THIS DRAWING IS THE ONLY PROPERTY OF SHARP ENGINEERS  
 ANY REPRODUCTION IN PART OR AS WHOLE WITHOUT THE WRITTEN PERMISSION OF SHARP  
 ENGINEERS IS PROHIBITED.

|              |             |      |             |                         |            |       |  |                       |
|--------------|-------------|------|-------------|-------------------------|------------|-------|--|-----------------------|
| REVISION No. | DESCRIPTION | DATE | APPROVED BY | DRWN BY<br>KM           | SIZE<br>A4 | SCALE |  | TITLE:-               |
|              |             |      |             | DRWN DATE<br>05-06-2020 |            |       |  | SEG-30<br>G.A.DRAWING |



THE INFORMATION CONTAINED IN THIS DRAWING IS THE ONLY PROPERTY OF SHARP ENGINEERS ANY REPRODUCTION IN PART OR AS WHOLE WITHOUT THE WRITTEN PERMISSION OF SHARP ENGINEERS IS PROHIBITED.

ALL DIMENSION ARE IN MM UNLESS OTHERWISE SPECIFIED.

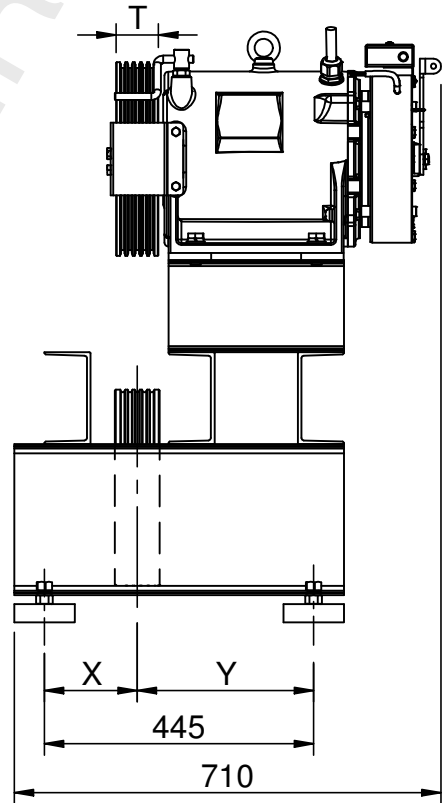
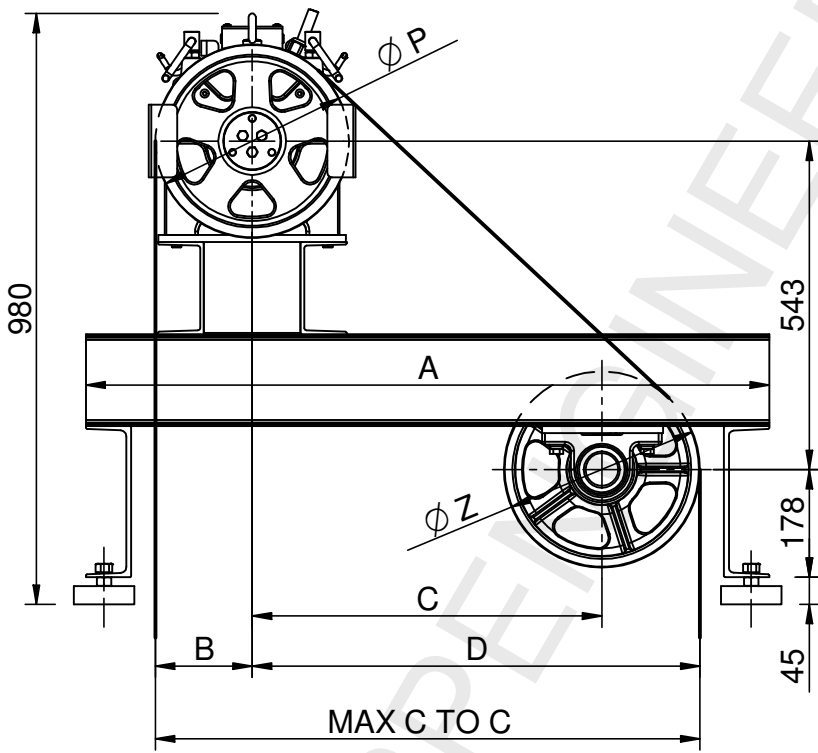
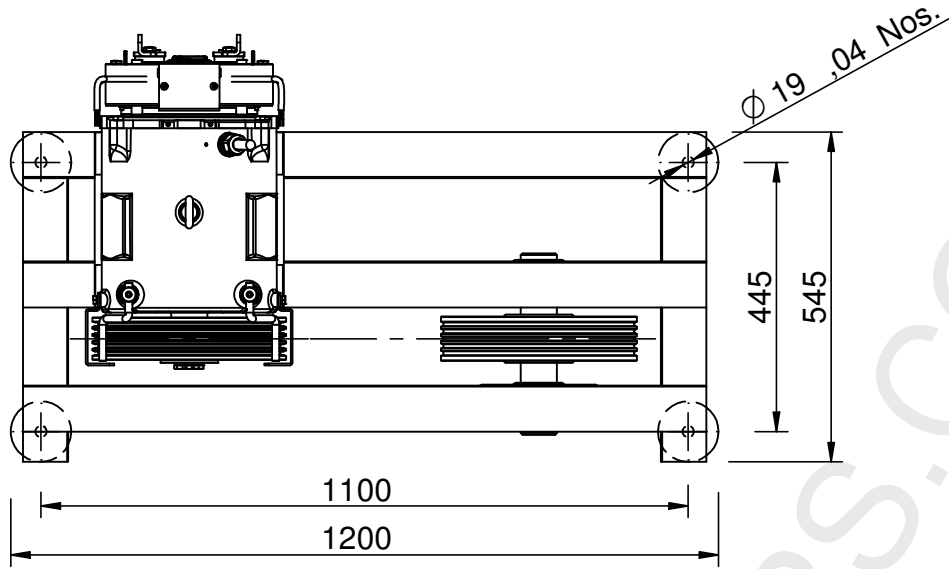

| MAIN SHEAVE ØP | MAIN SHEAVE THICKNESS T | DIVERTER PULLEY ØZ | MAX C TO C | A    | B   | C   | D   | X     | Y     |
|----------------|-------------------------|--------------------|------------|------|-----|-----|-----|-------|-------|
| Ø240           | 97                      | Ø320               | 900        | 1160 | 120 | 620 | 780 | 140   | 305   |
| Ø240           | 119                     |                    |            |      |     |     |     | 129   | 316   |
| Ø320           | 82                      |                    |            |      |     |     |     | 147.5 | 297.5 |

| REVISION No. | DESCRIPTION | DATE | APPROVED BY |
|--------------|-------------|------|-------------|
|              |             |      |             |

DRWN BY  
KM  
DRWN DATE  
10/01/2018

SIZE  
A4

SCALE

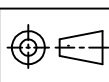

TITLE:-  
SEG-30  
CTOC DRAWING FOR MAX. 900mm

